

INSTALLATION AND OPERATING

AIRTHERM

Air Source Heat Pump

4.5, 9, 12

For users guide see reverse of book

When replacing any part on this appliance, use only spare parts that you can be assured conform to the safety and performance specification that we require. Do not use reconditioned or copy parts that have not been clearly authorised by Ideal.

For the very latest copy of literature for specification and maintenance practices visit our website www.idealheating.com where you can download the relevant information in PDF format.

Ideal airtherm 4.5, 9 & 12 Air Source Heat Pump

Destination Country: GB, IE



CONTENTS

How the Heat Pump Works.....	4
Introduction.....	5
Heating with a heat pump.....	5
Safety precautions	5
Location.....	6
Unpacking	6
Plumbing - pipework	7
Plumbing - buffer tank and hot water cylinder	7
Electrical.....	8
Electrical Connections.....	8
Internal wiring	8
Electrical Diagrams	9-10
Internal Machine Circuit Diagrams	11-12
Frost protection	13
Control Panel.....	13
Commissioning.....	14
Handing Over.....	14
Fault finding	15-16
Data sheet	17
Machine dimensions, access panels and electrical/water connections	18-20
System designs - S Plan.....	21-22
System designs - W Plan.....	23-24
System designs - Bivalent installation.....	25
Refrigeration Diagrams.....	26-27
Optional weather compensation.....	28
Mounting the sensor	29
Wiring of the Optional Weather Compensator.....	29
Heat Pump and Buffer Installation Req.....	30-33
Commissioning Checklist.....	34-35

HOW THE HEAT PUMP WORKS

The Ideal airtherm Heat Pump provides thermodynamic heating by means of a vapour compression cycle (similar to that employed in a conventional refrigerator), in addition to operating as an active solar collector.

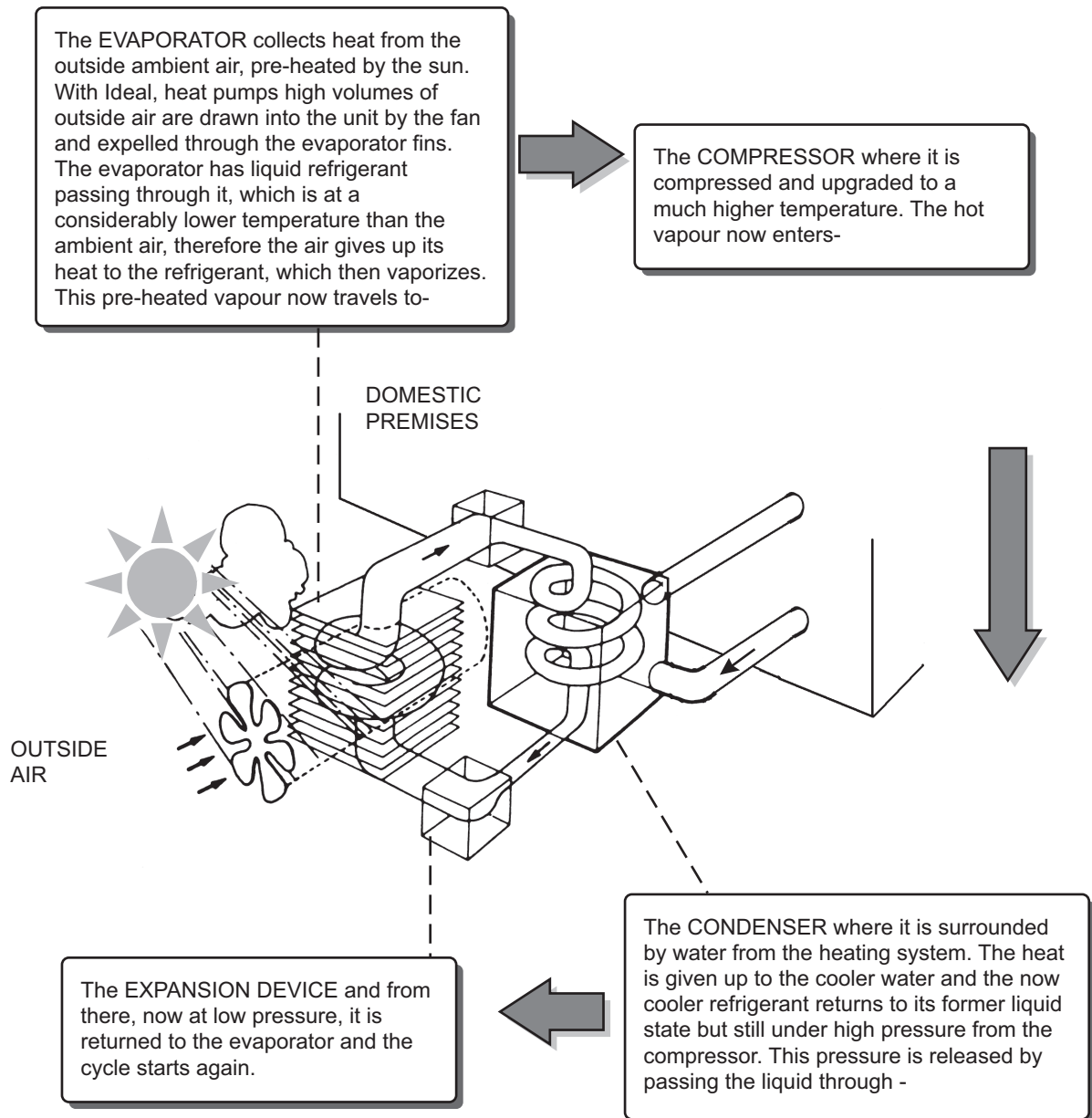

Coefficient of Performance

The efficiency of a Heat Pump is usually called its 'Coefficient of Performance' - (C.O.P.) which is simply a ratio of heat output to energy input, both being expressed in kW. Thus a Heat Pump absorbing 1 kW of electricity, collecting 4 kW of energy from the air, and delivering 5 kW of heat to the pool water is said to have a C.O.P. of 5:1. Naturally this ratio will vary according to the temperature of the water and the ambient air.

INTRODUCTION

This installation manual is accompanied by a user guide (see reverse of this book), a commissioning record sheet and a warranty registration card, all of which should be left with the householder. The user guide explains how the system works, how it is controlled and what to do in the event of a problem. The commissioning record sheet must be completed as its production will be required in the event of a warranty claim.

HEATING WITH A HEAT PUMP

The Ideal heat pump is designed to operate up to 65°C water temperature for the domestic hot water delivery, and negates the need for direct electrical heating in the form of an electrical immersion heater. The unit also provides space heating temperatures variable from 35°C to 55°C.

Heat pumps for domestic heating are a fully proven technology which will give many years of trouble-free service. Ideal Heat Pumps which are MCS approved have been specifically designed for optimum operation in the UK's climate.

However, unlike an oil or gas boiler which may be oversized for the heating demand of the property and therefore regularly cycles on and off, a heat pump is closely matched to the heat demand and is designed to run for long periods without switching on/off.

The following steps must therefore always be taken to ensure a successful installation. Major problems can occur if they are not taken and failure to comply will invalidate the warranty.

- a. SAP or equivalent heat loss calculations must be established with the results recorded on the commissioning sheet.
- b. The heat pump must be correctly sized in relation to the calculated heat losses.
- c. The space heating system must be capable of satisfying the heat demand at the water flow temperature set for the heat pump. This is particularly important where retro-fitting a heat pump to a radiator system designed originally for a Delta T of 60°C, as the heat pump will run at a Delta T of 30°C. In this situation, you will normally need to fit larger radiators.
- d. The electrical supply must be adequate to meet the start current demand.
- e. The heat pump and the associated heating system must be commissioned in accordance with the procedures laid down in this manual.

A heat pump may be fitted on a stand-alone basis (monovalent system) to satisfy the full heating and hot water demand of the property or in parallel with an existing boiler (bivalent system).

In the case of a bivalent installation the heat pump is sized to provide a variable proportion of the annual heating requirement (say 85%) with the existing boiler integrated to deliver the balance on the coldest days. In bivalent systems, the heat pump is sometimes only linked to the space heating system which eliminates the requirement to fit a new DHW cylinder.

Standard designs for several different configurations, including plumbing and electrical circuits, are included in this manual.

REGULATIONS

The Ideal airtherm models confirm

- *BS EN60335-1:2002 & 2-40:2003, and therefore comply with the Low Voltage Electrical Equipment Directive 73/23/EEC; 93/68/EC.*
- *BS EN ISO 12100-1:2003, BS EN ISO 12100-2:2003, BS EN ISO 13857:2008: BS EN ISO 13850:2006, and therefore comply with the Supply of Machinery (Safety) Directive 98/37/EC.*
- *BS EN55014-1:2000+A1:2001+ A2:2002, 14-2:1997+A1:2001, EN61000-3-2:2000, -3-3:1995 + A1:2001, -4-2:1995, -4-3:1996, -4-4:1995, -4-5:1995, -4-6:1996, -4-11:1995. and therefore comply with the Electromagnetic Compatibility Directive 2004/108/EC.*
- *Comply with the Pressure Equipment Directive 97/23/EC, Fluid Group 2, Category 1.*
- *Compliant to RoHS Directive 2002/95/EC*

SAFETY PRECAUTIONS

- a. The unit must be securely installed on a structure that can sustain its weight. If mounted on an unstable structure, it may fall causing injury or damage.
- b. If the heat pump is installed in an enclosed area, sufficient ventilation must be provided so as not to impede the air flow through the unit and to prevent the concentration of refrigerant gas in the room building up in the event of a leak. (See diagram - page 6)
- c. All electrical work must be performed by a qualified technician and comply with the latest I.E.E (17th) Regulations. The machine should be installed in accordance with EMC 2004/108/EC.
- d. Electricity to the unit must be supplied through dedicated power lines and the correct voltage and circuit breakers must be used. Power lines with insufficient capacity or incorrect electrical work may result in electric shock or fire. The electrical ratings of Ideal heat pumps are included in the datasheet on page 16 of this manual.
- e. Any external heating device fitted to the plumbing circuit of the heat pump must have its own thermostatic control safety cut out.
- f. Immersion heater elements in any hot water tank must have a built in thermostat.

INSTALLATION

LOCATION

The heat pump is suitable for outside installation.

- Select a location where any potential noise disturbance is minimised.
- Provide a firm level base capable of supporting the weight of the machine. Fixing holes are provided for bolting the machine down to the base.
- If wall mounting, ensure that the wall and framework are capable of supporting the machine and use anti-vibration mounts to prevent noise transmission. The weights of the heat pumps are included on the data sheet on page 16 of this manual.
- If installing in a location exposed to strong wind, do not face the air outlet of the unit against the direction of the wind as wind entering the unit may impede the normal airflow and result in a malfunction.
- Allow for the minimum clearances around the machine, as shown below, required for unobstructed air flow and access to service panels. A clearance of 1 metre above the unit is recommended for servicing access through the top panel.
- Consider protection from extreme weather conditions with a

cover or enclosure if the machine is installed externally

- Consider fitting a protective guard where the machine could be exposed to vandalism or other damage.
- If installed in a plant room or other building, ensure that the air outlet is positioned directly adjacent to the outside wall with inlet and discharge grilles or apertures of minimum free areas as detailed below.

TYPICAL INSIDE OR PLANT ROOM INSTALLATION

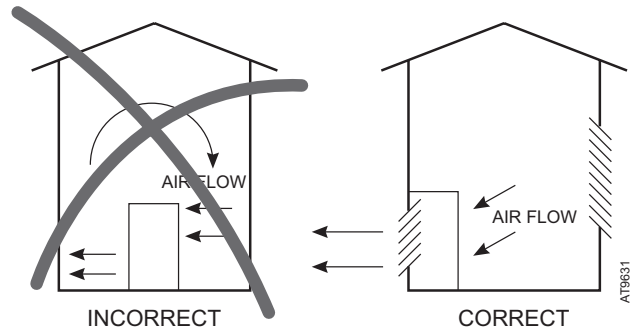

Grill or apertures MUST comply with Figures (See Table 1)

Table 1

Model	Minimum Free Area m ²	
	Inlet	Discharge
airtherm 4.5	0.440	0.114
airtherm 9	0.440	0.114
airtherm 12	0.619	0.1313

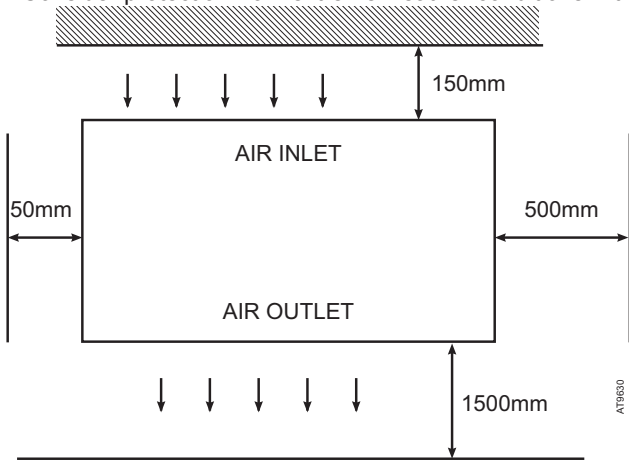

UNPACKING

- Position the heat pump close to point of installation on a sound flat surface and in an area large enough to unpack the unit.
- Carefully remove the plastic strapping securing the unit and carton sleeve to the pallet.
- Fold back the top flaps to gain access to the literature pack.
- Remove the instructions and read thoroughly before unpacking the product.
- When ready for installation lift off the cardboard carton sleeve.
- Carefully remove the unit from the pallet.

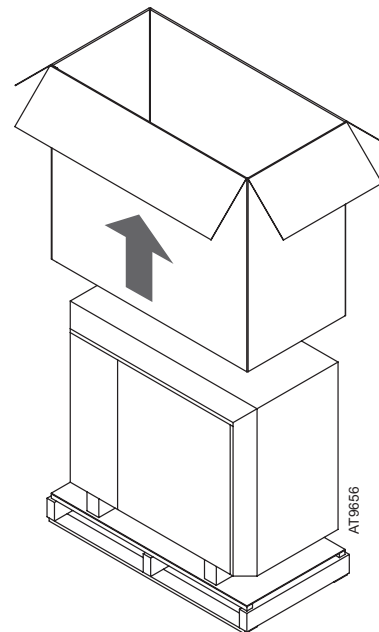

INSTALLATION

PLUMBING - PIPEWORK

- a. Ideal heat pumps have water flow and return connections as follows:
- The airtherm 4.5 and 9 models have ¾" BSP parallel, male threads
 - The airtherm 12 has 1" BSP, parallel, male threads
- b. Couplings suitable for disconnection should be installed with isolating valves on the flow and return of the heat pump to ease installation and maintenance. During the initial installation, these should be the last connections made so as to avoid any stresses on the unit connections.
- c. A drain valve or plug should be fitted to the lower pipe to facilitate drain down for servicing.
- d. The condensate drain at the base of the unit collects the condensation from the evaporator fins. This should be run away to waste from the ¾" PVC pipe on the side of the heat pump. The routing of the drain must be made to allow a minimum fall of 1 in 20 away from the unit, throughout its length.
- e. Do not allow pipe work to run in front of service panels.
- f. All pipe work must be adequately supported with allowance for expansion/contraction and should be insulated to avoid unnecessary heat loss.

PLUMBING - BUFFER TANK AND HOT WATER CYLINDERS

Refer to Page 31-33 for addition information

- a. The Ideal air source heat pump is normally designed to operate with a buffer tank which prevents short cycling during normal operation and provides a thermal store to aid defrost of the heat pump. The size of the buffer tank needed varies with the size of the ASHP unit as shown below.
- b. Where the ASHP is required to supply domestic hot water, a special DHW cylinder (Ideal cylinder) should be purchased with each air to water heat pump. These cylinders have a larger primary coil compared to standard cylinders and are supplied with a special tank thermostat. An immersion heater is fitted for back-up DHW heating and must contain a built in thermostat.
- c. Where indirect pressurised cylinders are fitted, they should be installed in compliance with the relevant Water Regulations and Building Regulations.

HEAT PUMP	BUFFER TANK CAPACITY
airtherm 4.5	50 litres
airtherm 9	95 litres
airtherm 12	150 litres

INSTALLATION

ELECTRICAL

- a. A separately fused single phase supply is required. With all power switched off, remove the electric's access panel to gain access to the terminals in the electric box. The supply cable, entering the unit through knock outs in the panel, can then be fed through to connect into the live/neutral/earth terminals.
 - b. An MCB type C or D or correctly rated fuse must be used. (Refer to data sheet on page 17 of this manual).
 - c. A local isolator should be fitted within 2 feet of the unit to comply with I.E.E. regulations. Power to the unit is indicated by the red indicator light on the console (mains lamp).
 - d. A separate fused spur is normally used to supply the central heating programmer and controls.
 - e. There are 10 connections to be made between the Ideal heat pump and the control wiring centre. A multi core cable with sufficient capacity will need to be provided and installed. In most cases a 12 core 0.5mm control cable is used.
 - f. The unit may be live even when the mains lamp is off
- due to live feeds from the external control system. The 'programmer live' light on the control panel confirms the presence of a supply. (See diagram page 13).
- g. The heat pump can operate in one of two modes, either set as supplied, with the unit biased to hot water, or with no bias for hot water or heating.
 - h. Ideal Boilers would always recommend a system with the heating biased to hot water. However if room heating and hot water heating are required at the same time, the link between terminals 11 and 12 should then be fitted. There is then no bias between room heating and hot water heating.
- Notes:-
- i. Where the link is fitted the unit will deliver 65°C flow temperature during periods of DHW demand and this must be considered at system design with consideration to this temperature feeding radiators or under floor heating at these times.
 - ii. The link cannot be fitted when the heat pump is plumbed in to a 'W Plan' system.

ELECTRICAL CONNECTIONS

- a. The electrical connections diagrams are on pages 9 and 10 of this manual.
- b. The wiring junction box is located behind the access panel below the unit's control panel
- c. For the heat pump to operate, you must have a live signal into terminal 9 (space heating) and terminal 1 (DHW).

INTERNAL WIRING

- a. Internal wiring diagrams are on pages 11 and 12 of this manual.
- b. External wiring will depend on the heating system design and is found on pages 22 & 24 of this manual.

INSTALLATION

ELECTRICAL CONNECTIONS IDEAL AIRTHERM 4.5 & 9

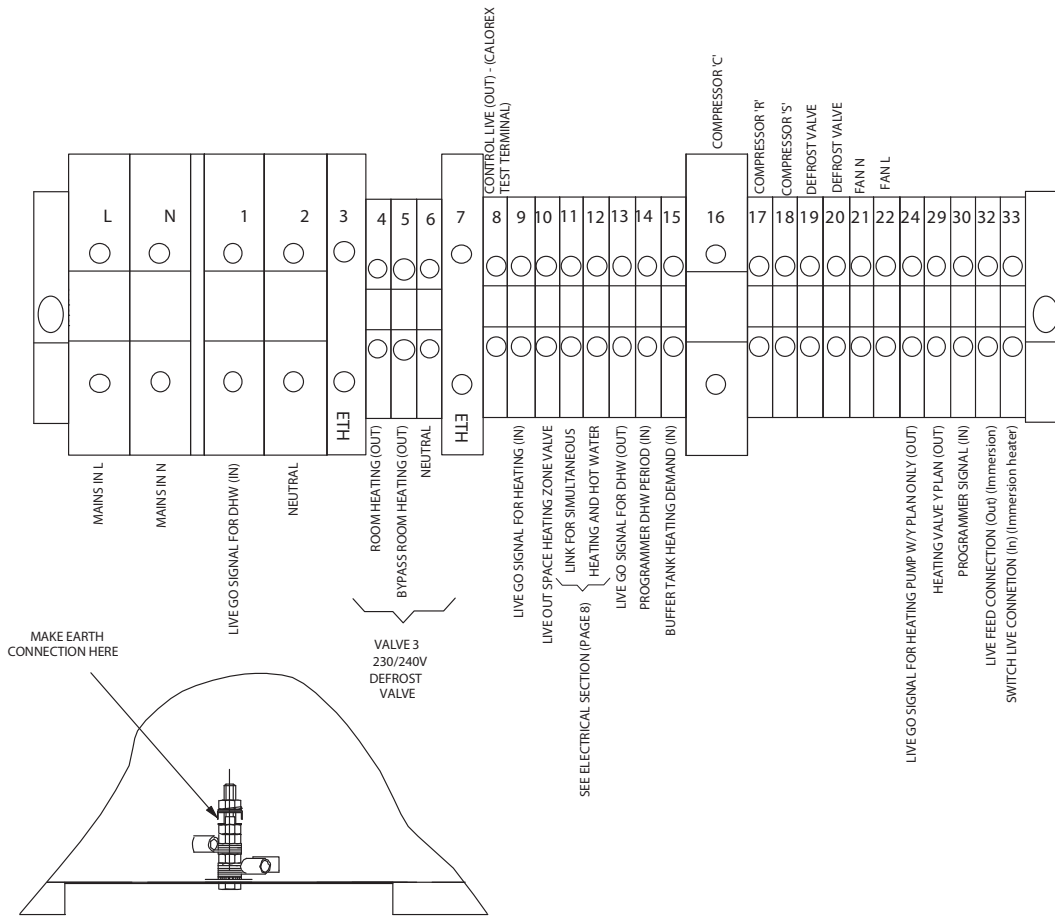

Heat Pump Terminal	Connections	Connect to:-		Notes
		S Plan Connections AW45002/AW9002 External Wiring Connections	W Plan Connections AW45002/AW9002 External Wiring Connections	
Live	Mains Power Supply			
Neutral				
Earth				
1	Live Go for Programmer for DHW	18	18	
2	Neutral	19	19	
3	Earth	20	20	
4	Live Out Space Heating			Defrost Terminals
5	Live Out Defrost	23	23	
6	Neutral			
7	Earth			
8	Programmer Live Calorex Test Terminal			
9	Live Go from Programmer for Space Heating	16	16	
10	Live Out Space Heating Zone Valve	17	17	
11	Link for Simultaneous Space Heating / DHW			Add link if Required
12	Link for Simultaneous Space Heating / DHW			
13	Live Out DHW Zone Valve	7		
14	Live in from Programmer for DHW Time Clock	11	11	
15	Buffer Tank Stat / Ambient Stat Live in (DHW Only)	22	22	
16-23	Internal Connections			
24	Live Out Circulating Pump		7	
29	Zone Heating Valve (Live out Y Plan Only)			
30	Live in from Programmer (Programmer Live Lamp)	2	2	
32	Live Feed Connection (Out) (Immersion)	24		
33	Switch live Connection (In) (Immersion heater)		25	

INSTALLATION

ELECTRICAL CONNECTIONS IDEAL AIRTHERM 12

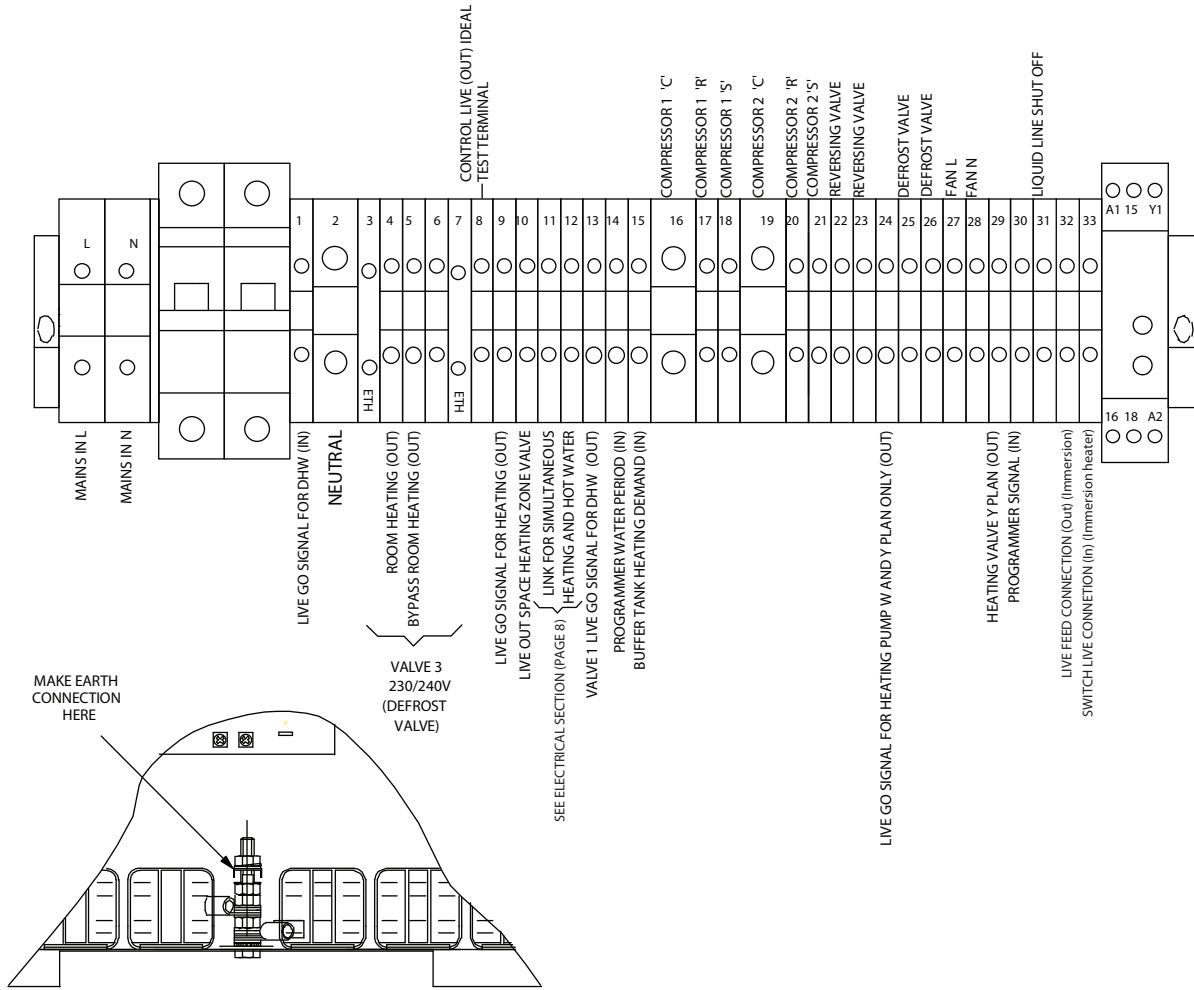

Heat Pump Terminal	Connections	Connect to:-		Notes
		S Plan Connections AW12002 External Wiring Connections	W Plan Connections AW12002 External Wiring Connections	
Live	Mains Power Supply			
Neutral	Mains Power Supply			
Earth	Mains Power Supply (Earth Stud)			
1	Live Go for Programmer for DHW	18	18	
2	Neutral	19	19	
3	Earth	20	20	
4	Live Out Space Heating			Defrost Terminals
5	Live Out Defrost	23	23	
6	Neutral			
7	Earth			
8	Programmer Live Calorex Test Terminal			
9	Live Go from Programmer for Space Heating	16	16	
10	Live Out Space Heating Zone Valve	17	17	
11	Link for Simultaneous Space Heating / DHW			Add link if Required
12	Link for Simultaneous Space Heating / DHW			
13	Live Out DHW Zone Valve	7		
14	Live in from Programmer for DHW Time Clock		11	
15	Buffer Tank Stat / Ambient Stat Live in (DHW Only)	22	22	
16-23	Internal Connections			
24	Live Out Circulating Pump		7	
29	Zone Heating Valve (Live out Y Plan Only)			
30	Live in from Programmer (Programmer Live Lamp)	2	2	
31	Internal Connection			
32	Live Feed Connection (Out) (Immersion)	24		
33	Switch live Connection (In) (Immersion heater)		25	

INSTALLATION

INTERNAL MACHINE CIRCUIT DIAGRAM - AIRTHERM 12

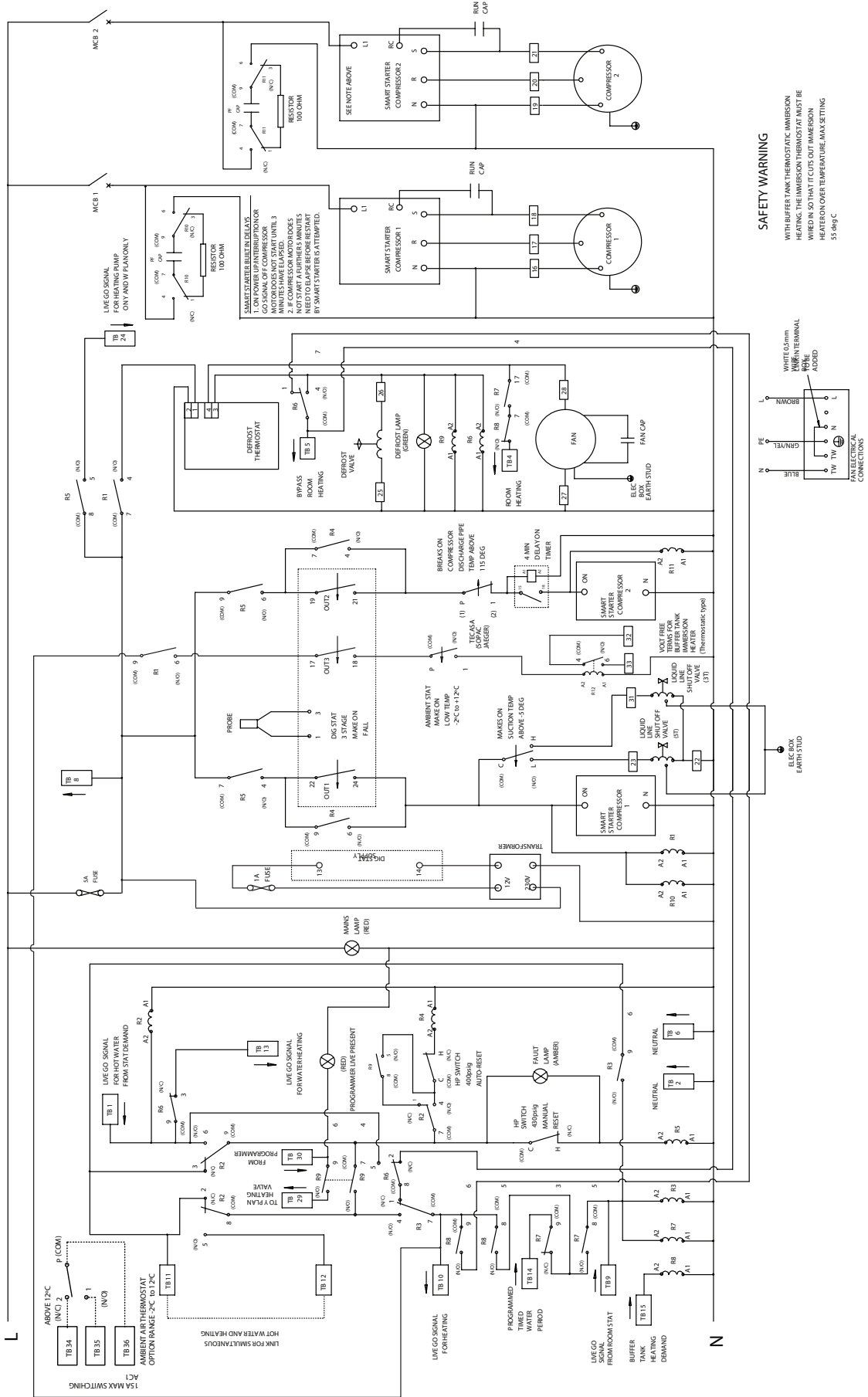

INSTALLATION

FROST PROTECTION

Frost protection of the heating circuit is essential. We recommend the use of a combined inhibitor/anti-freeze, either Fernox Alpha 11 or Sentinel X500. The manufacturers' recommendations on concentration should be followed.

A minimum concentration of 15% to 20% is needed to avoid any risk of corrosion. A 30% concentration gives frost protection down to -15°C, the minimum operating temperature for the ASHP.

When an inhibitor/anti-freeze is used, the water flow and pressure drop need to be increased to the levels shown below.

		airtherm 4.5	airtherm 9	airtherm 12
Water flow +/-20%	litres/min	8.3	16.5	22.0
Pressure drop (water)	Metres head	1.7	1.0	0.5

Correct water flow is essential for reliable operation of the heat pump. Using the information in the table above and total system pressure drop the selection of an appropriate water circulation pump can be made. Consult water circulation pump manufacturers data sheets for accurate water pump performance.

When the correct water pump has been selected a Delta 'T' of 3°C to 5°C between water in-let to outlet temperature indicates correct flow rate.

Where frost protection is provided by the thermostats that control the unit, the water flow and pressure drop should be set to the values shown in the data sheet on page 17 of this manual.

CONTROL PANEL

All units have integral safety devices to protect the heat pump from integral and external faults and indicator lamps showing operating mode. An adjustable digital thermostat controls space heating and return water temperature. Also a three minute cycle time delay which protects the compressor is incorporated.

The control panel is located on the right side of the unit under the upper removable steel panel.

1. To access, carefully remove the plastic screw covers and the screws and washers beneath. Place these to one side, ready for re-assembly.
2. Slide the controls cover from the upper location slots and place to one side.
3. Re-assembly is in reverse order, taking care to use the washers correctly to enable the screw caps to be replaced.

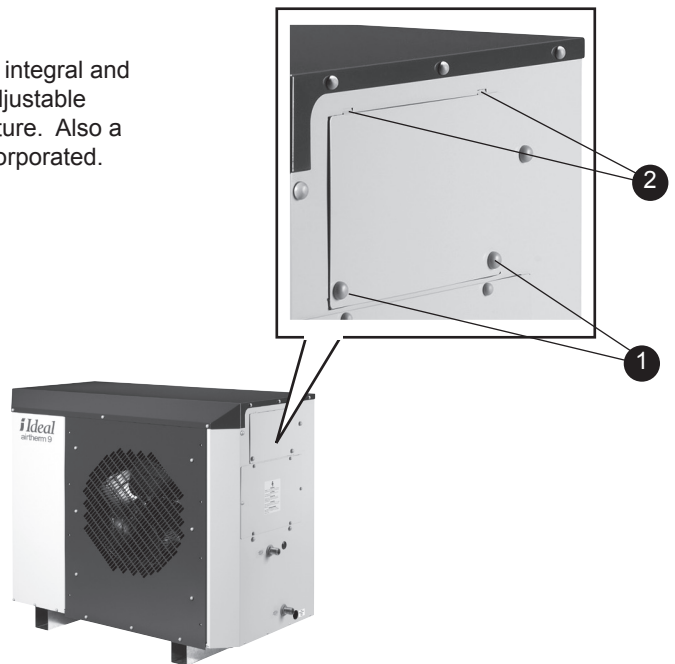

LEGEND

- A** Space Heating Temperature Controller
- B** Mains Lamp (red)
- C** Defrost Lamp (Green)
- D** Programmer Live Lamp (red)
- E** High Pressure Switch Manual Reset
- F** Fault Lamp (amber)
(contact service engineer if high pressure reset does not clear fault)

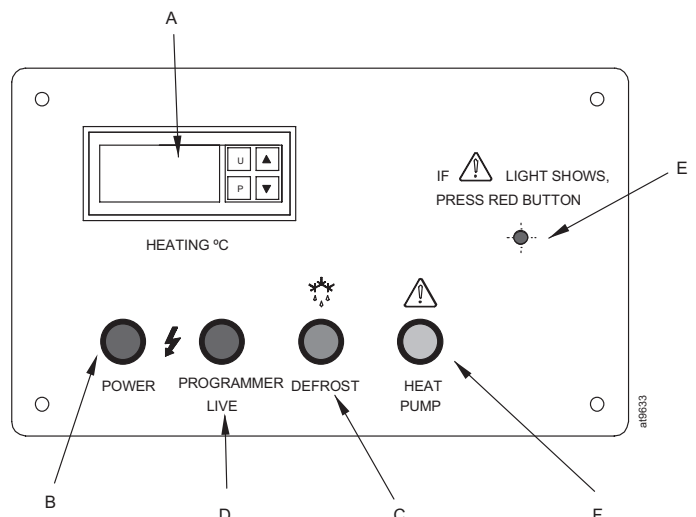

INSTALLATION

COMMISSIONING

- a. Ensure that all water circuits are clean, purged, leak tested, fully de-aerated and correctly balanced.
- b. Add inhibitor/anti-freeze in the correct concentration to ensure frost protection. This is essential, unless frost protection is ensured by thermostats.
- c. The control panel for the air source heat pump is located under a secure cover on the right hand side of the machine.
- d. Check that all wire connections are correctly made and tight
- e. Switch on power at the distribution board and check that there is mains power to the unit.
- f. Check that the control system is switched on and that the red 'programmer live' lamp is lit.
- g. DHW system tests
 - i. Set the programmer to DHW and set the cylinder stat to the required temperature
 - ii. Switch the heat pump on. *When first turned on, the machine will go into defrost with the compressor running, the fan off and the green light on. This defrost cycle will run for about 4 minutes.*
 - iii. Check that the system valves operate correctly
 - iv. Check for an increase of 2-3°C in the return water temperature displayed on the unit control panel. This will confirm that the system is working.
- h. Central heating system tests

The space heating temperature controller is used to adjust the return water temperature from the space heating system. For maximum economy, this should be set to the lowest acceptable level.

The setting is adjusted by first pressing and then releasing button P followed by pressing the up or down arrow buttons to display the required temperature. Button P should be pressed again to confirm your settings.

After 5 seconds the display will revert to the actual water temperature.

The amber fault lamp indicates a possible problem in the system. This may be cleared by the manual reset of the high pressure switch (red recessed button). If the fault proves difficult to clear, check that all plumbing and electrical connections are made in accordance with this manual and that the system characteristics required in the data sheet on page 16 of this manual (water flow rates etc) have been achieved.

The green defrost lamp is illuminated when the heat pump is defrosting.

- i. Set the programmer to central heating.
 - ii. Turn the room thermostat up to 30°C, at which point the water circulating pump should start followed by the compressor and fan. Note; there may be a time delay of 6 mins before the compressor starts - this is normal.
 - iii. Check that the system valves operate correctly
 - iv. Check for an increase in the return water temperature and for an increase in the radiator temperatures. The initial heat-up of an under floor system will take many hours.
 - v. Once the system is running correctly, turn any thermostatic radiator valves to the required settings and set the room thermostat to 21/22°C.
- i. Check that the chosen electricity tariff provides the optimum economy in relation to the occupant's lifestyle and heating demand. When replacing electric storage radiators, note that the Economy 7 or equivalent tariff may not be appropriate for the economic operation of an air source heat pump.
 - j. Check that the time clock is set to suit the occupant. Where a controller is fitted which features multiple time/temperature periods, set these individually to suit the occupant.
 - k. Ensure that all service panels are securely fitted with the tamper proof screws.
 - l. A fault finding chart is provided on page 15 of this manual.
 - m. Complete the commissioning sheet on page 34 of this manual.



















HANDING OVER

- a. Hand the user instructions to the householder and explain his/her responsibilities under the relevant regulations.
- b. Explain the start and shut down procedures.
- c. The operation of the heat pump and the use and adjustment of all system controls should be fully explained to the householder, to ensure the greatest economy consistent with heating and hot water household requirements.
- d. Advise the user of the precautions necessary to prevent damage to the system and heat pump.
- e. Explain the function of pump fault light.
- f. Loss of system water pressure - Explain that the system pressure gauge indicates the central heating system pressure and that if the normal COLD pressure of the system is seen to decrease over a period of time then a water leak is indicated. Explain the re-pressurising procedure and if unable to re-pressurise or if the pressure continues to drop a registered local heating installer should be consulted.

INSTALLATION

FAULT FINDING

- a. The user checklist below should be carried out before initiating a service call.
- b. Do not attempt to interfere with any internal control settings as these have been factory calibrated and sealed.
- c. If in doubt or if advice is required, contact the Ideal Service department on 01482 492251.

LAMP		ACTION		
UNIT DOES NOT OPERATE				
POWER	RED		OFF	} Check mains supply - external fuses - isolator etc.
FAULT	AMBER		OFF	
DEFROST	GREEN		OFF	
PROGRAMMER LIVE	RED		OFF	
MAINS	RED		ON	} Check supply to programmer
FAULT	AMBER		OFF	
DEFROST	GREEN		OFF	
PROGRAMMER LIVE	RED		OFF	
POWER	RED		ON	} Check water and air flows are not restricted } Check Heating pump(s)
FAULT	AMBER		ON	
DEFROST	GREEN		OFF	
PROGRAMMER LIVE	RED		ON	
FAN OFF COMPRESSOR ON				
POWER	RED		ON	} Unit on defrost } Check evaporator is clean
FAULT	AMBER		OFF	
DEFROST	GREEN		ON	
PROGRAMMER LIVE	RED		ON	
NO ROOM HEATING OR HOT WATER - UNIT NOT OPERATING				
POWER	RED		ON	} Is programmer set to an "ON" period } Check input in terminal 1 or 9
FAULT	AMBER		OFF	
DEFROST	GREEN		OFF	
PROGRAMMER LIVE	RED		ON	
NO ROOM HEATING OR HOT WATER - UNIT OPERATING				
POWER	RED		ON	} Check domestic heating system
FAULT	AMBER		OFF	
DEFROST	GREEN		OFF	
PROGRAMMER LIVE	RED		ON	

AT9634

The machine is fitted with a "Smart Starter" (situated on electrics panel) which prevents damage to the compressor within the heat pump. This smart starter has an LED which indicates fault conditions as follows:

- Ready to accept a start command: a double blink every 5 seconds.
- 3 minute cycle delay: 1 flash per second.
- Fault mode: slow flash, 5 sec on, 5 sec off.
- Low voltage: fast flash, 10 per second.

INSTALLATION

ASHP Operation Check List S-Plan System

DHW Priority Note: Link OUT - ASHP TB11 & TB12 ** Programmer should be set to separate DHW and Heating time periods

Demand	Valve position	Signals To Valve (230V)	Inputs into ASHP (230V)	Outputs from ASHP (230V)	Notes
DHW Only	DHW OPEN	TB13	TB1, TB14, TB30	TB13	output on TB4, TB24 not used
Both**	DHW OPEN	TB13	TB1, TB14, TB9, TB30	TB13	output on TB4, TB24 not used
Heating only	HEATING OPEN	TB10	TB9, TB30	TB10	output on TB4, TB24 not used
Defrost	HEATING OPEN	TB10	TB30, TB9, or TB14, TB1, TB30	TB10, TB5	output on TB4, TB24, TB29 not used

DHW & Heating Note: Link IN - ASHP TB11 & TB12

Demand	Valve position	Signals To Valve (230V)	Inputs into ASHP (230V)	Outputs from ASHP (230V)	Notes
DHW Only	DHW OPEN	TB13	TB1, TB14, TB30	TB13	output on TB4, TB24 not used
Both	HEATING & DHW OPEN	TB10, TB13	TB1, TB14, TB9, TB30	TB13, TB10	output on TB4, TB24 not used
Heating only	HEATING OPEN	TB10	TB9, TB30	TB10	output on TB4, TB24 not used
Defrost	HEATING OPEN	TB10	TB30, TB9 or TB14, TB1, TB30	TB10, TB5	output on TB4, TB24, TB29 not used

Buffer Demand via Buffer tank stat and ambient stat

Demand	Valve position	Signals To Valve (230V)	Inputs into ASHP (230V)	Outputs from ASHP (230V)	Notes
DHW Only	HEATING & DHW OPEN	TB10, TB13	TB1, TB14 & TB15, TB30	TB10, TB5, TB13	Buffer Tank heated to setting
Both	HEATING & DHW OPEN	TB10, TB13	TB1, TB14, TB9, TB15, TB30	TB10, TB5, TB13	Buffer Tank heated to setting
Heating only	HEATING OPEN	TB10	TB9, TB15, TB30	TB10	Buffer Tank already being heated

ASHP Operation Check List W-Plan System

DHW Priority Notes: Link OUT - ASHP TB11 & TB12 **Programmer should be set to separate DHW & Heating time periods

Demand	Valve position	Signals to Valve	Inputs into ASHP (230V)	Outputs from ASHP (230V)	Notes
DHW Only	spring return to DHW	none	TB1 & TB14, TB30	230V TB24	output on TB4, TB13 not used
Both**	spring return to DHW	none	TB1, TB14, TB9, TB30	230V TB24	output on TB4, TB13 not used
Heating only	heating open	230V from TB10	TB9, TB30	230V on TB10, TB24	output on TB4 not used
Defrost	heating open	230V from TB10	TB30, TB9 or TB1, TB14, TB30	230V on TB10 & TB5, TB24	output on TB4, TB29 not used

Buffer Demand via Buffer tank stat and ambient stat

Demand	Valve position	Signals to Valve	Inputs into ASHP (230V)	Outputs from ASHP (230V)	Notes
DHW Only	Heating- open	230V from TB10	TB1, TB14, TB15, TB30	230V on TB10, TB5, TB24	Buffer Tank heated to setting
Both	Heating- open	230V from TB10	TB1, TB14, TB9 TB15, TB30	230V on TB10, TB5, TB24	Buffer Tank heated to setting
Heating only	Heating- open	230V from TB10	TB9, TB15, TB30	230V on TB10, TB5, TB24	Buffer Tank already being heated

INSTALLATION

DATASHEET

MODEL	UNITS	AIRTHERM 4.5	AIRTHERM 9	AIRTHERM 12
DUTY				
Air on 0°C 90% RH *(@ DESIGN WATER FLOW)				
OUTPUT TO WATER (@55°C) #	kW	2.97	5.63	7.86
ELECTRICAL INPUT	kW	1.54	2.93	3.98
OUTPUT TO WATER (@35°C) #	kW	3.39	6.56	9.11
ELECTRICAL INPUT	kW	1.11	2.17	2.93
Air on 7°C 87% RH *(TO EN 14511-2-2007)				
OUTPUT TO WATER (@35°C) #	kW	4.40	8.40	11.70
ELECTRICAL INPUT	kW	1.18	2.27	3.13
C.O.P. (SEE NOTE 6)				
		3.72	3.70	3.70
Air on 2°C 60% RH *(@ DESIGN WATER FLOW)				
OUTPUT TO WATER (@55°C) #	kW	6.10	11.44	15.92
ELECTRICAL INPUT	kW	1.78	3.35	4.54
OUTPUT TO WATER (@35°C) #	kW	6.30	11.81	16.50
ELECTRICAL INPUT	kW	1.37	2.58	3.51
DUTY				
ELECTRICAL SUPPLY 1 PHASE	V/ph/Hz		230/240V-1N/50Hz	
MINIMUM SUPPLY CAPACITY	amps	13	25	32
AMBIENT 10°C WATER 24°C	kWh	1.8	2.3	3.1
AMBIENT 20°C WATER 24°C	kWh	2	2.5	3.3
MAXIMUM SUPPLY FUSE 1ph N/ TYPE C MCB	amps	15.0	32.0	40.0
MAXIMUM STARTING CURRENT STD (LRA) 1 ph	amps	58.0	108.0	76.0
RLA 1ph	amps	10.1	18.8	12.9
SOFT START AMPS 1ph N	amps	19	35	31
IP Rating		24	24	24
WATER FLOWS ETC.				
WATER FLOW ± 20%	litres/min	7.5	15	20
PRESSURE DROP (WATER)	metres hd	1.1	0.7	0.4
CONDENSER VOLUME	litres	2.0	3.5	6.5
WATER CONNECTIONS	inches	3/4" BSPM	3/4" BSPM	1" BSPM
CONDENSATE WATER CONNECTIONS	inches		3/4" DOMESTIC WASTE	
MAIN FAN				
AIR FLOW (Anemometer @ air on grille. Wet evaporator)	m3/hr	3266	3000	4330
MAX EXTERNAL STATIC PRESSURE STD	mm Wg	0	0	0
MAX EXTERNAL STATIC PRESSURE F	mm Wg	6	6	6
FLA:- 1 ph N	amps	0.7	0.7	0.7
GENERAL DATA				
Hermetic System				
GAS CHARGE R134a	kg	3.5	5.5	7.5
OIL TYPE (COMPRESSOR)			POLYOLESTER OIL	
PHYSICAL DIMENSIONS				
WIDTH (Un-packed)	mm	1145	1145	1585
DEPTH (Un-packed)	mm	567	567	617
HEIGHT (Un-packed)	mm	958	958	958
WEIGHT (Un-packed)	kg	127	164	235
SOUND PRESSURE @ 1 metre	dB(A)	57	58	60
SOUND PRESSURE @ 10 metre	dB(A)	37	38	40
SOUND POWER TO ENV 12102	dB(A)	68	69	71

NOTES.

1. Weight and dimensions nett

2. Application limits: Lower limit of use to EN14511-4-2007, Outside heat exchanger = -6°C. 1m hd = 1.4 psi
 Potential Design lower limit of use, Outside heat exchanger = -15°C 1l/min = 0.22 gall
 Lowest entering temperature to EN14511-4-2007, Inside heat exchanger (water on) = 20°C
 (To ensure satisfactory defrosting this assumes industry standard water heat up times from 10°C to nominal UFH temperature of 35°C)
 Higher limit of use to EN14511-4-2007 Outside heat exchanger = 35°C
 Potential Design higher limit of use, Outside heat exchanger = 45°C
 Higher limit of use to EN14511-4-2007 Inside heat exchanger (water off) = 65°C

3. Allow 500mm clearance to service panels

4. Ideal reserve the right to change or modify models without prior notice

5. R134A global warming potential (GWP) 1300

6. The C.O.P. applies to NEW units with CLEAN heat exchangers.

* OUTDOOR HEAT EXCHANGER INLET TEMPERATURE

INDOOR HEAT EXCHANGER OUTLET TEMPERATURE

SPECIFIC PERFORMANCE CURVES CAN BE SUPPLIED BY IDEAL ON REQUEST

INSTALLATION

MACHINE DIMENSIONS, ACCESS PANELS AND ELECTRICAL/WATER CONNECTIONS

AIRTHERM 4.5

WATER IN/OUT CONNECTIONS 3/4" BSPM STUBS.
 CONDENSATE CONNECTION 3/4" BSPM STUB.
 ALLOW 500mm FOR ACCESS TO SERVICE PANELS

CUSTOMERS ELECTRICAL CONNECTIONS
 SEE WIRING DIAGRAMS

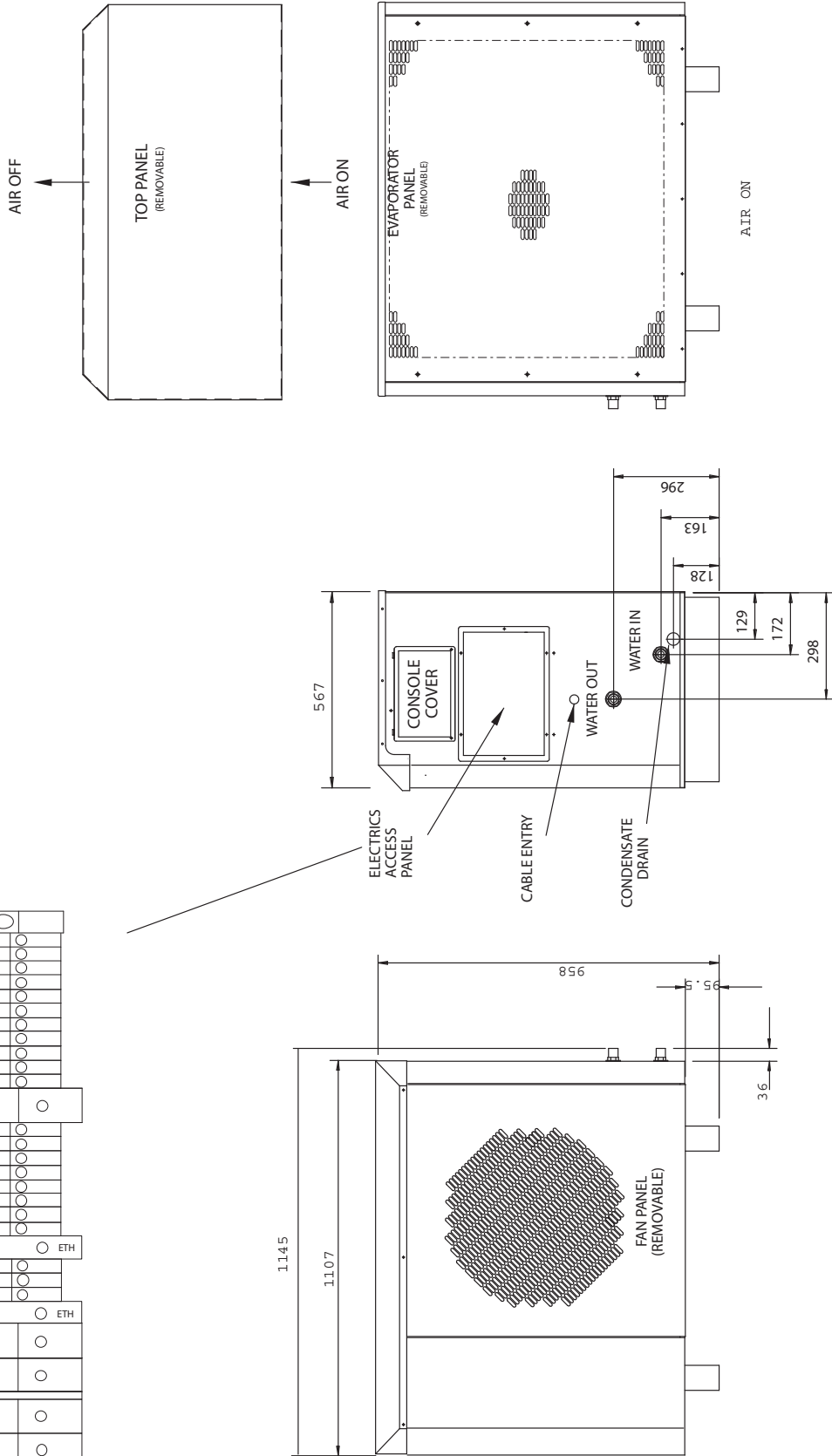
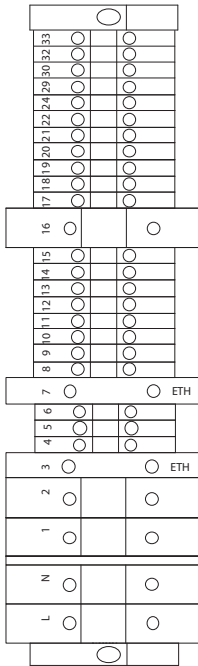

WARNING. DANGER FROM ELECTRIC SHOCK. ISOLATE ALL ELECTRICAL SUPPLIES BEFORE REMOVING ANY PANELS

INSTALLATION

MACHINE DIMENSIONS, ACCESS PANELS AND ELECTRICAL/WATER CONNECTIONS

AIRTHERM 9

CUSTOMERS ELECTRICAL CONNECTIONS
SEE WIRING DIAGRAMS

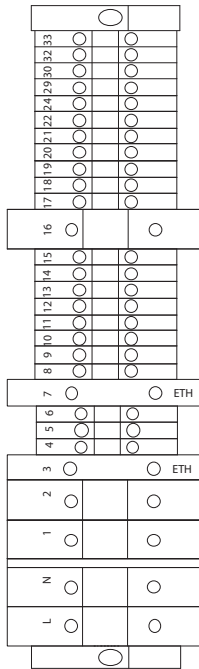

WATER IN/OUT CONNECTIONS 3/4" BSPM STUBS.
CONDENSATE CONNECTION 3/4" BSPM STUB.
ALLOW 500mm FOR ACCESS TO SERVICE PANELS

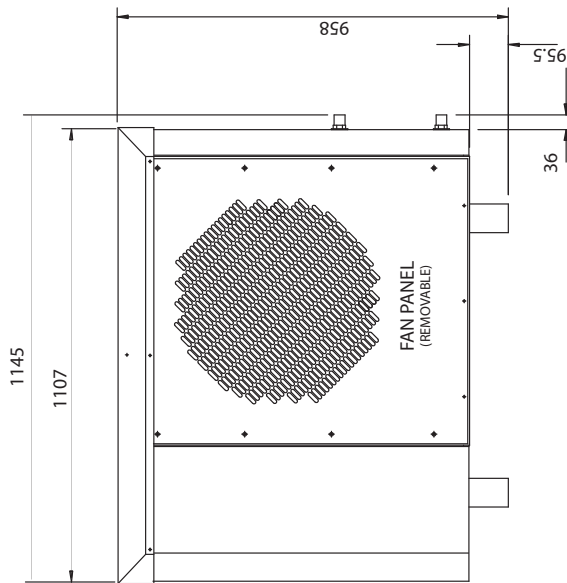
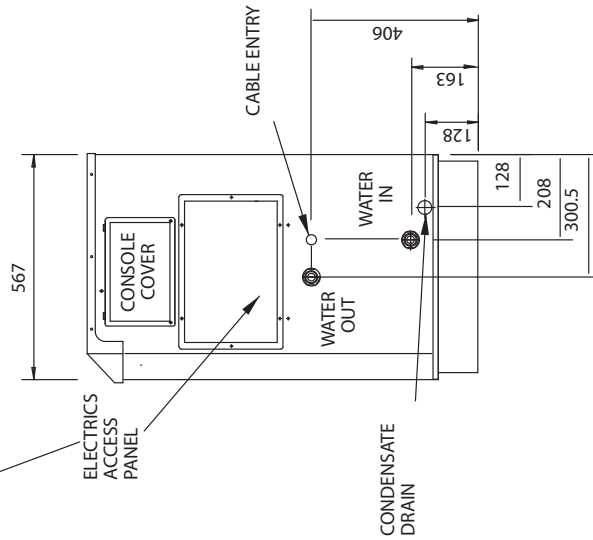
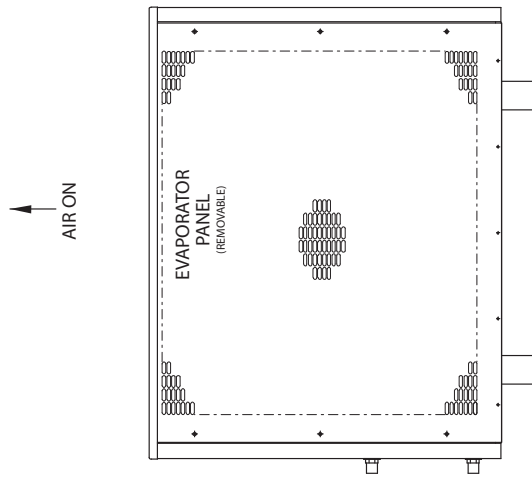
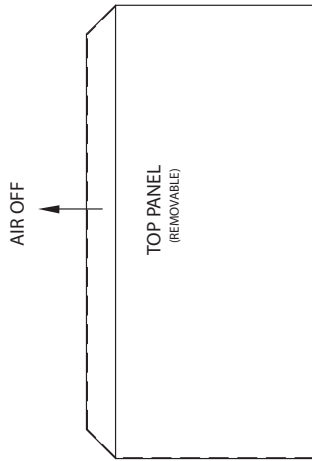

WARNING. DANGER FROM ELECTRIC SHOCK. ISOLATE ALL ELECTRICAL SUPPLIES BEFORE REMOVING ANY PANELS

INSTALLATION

MACHINE DIMENSIONS, ACCESS PANELS AND ELECTRICAL/WATER CONNECTIONS

AIRTHERM 12

CUSTOMERS ELECTRICAL CONNECTIONS
SEE WIRING DIAGRAMS

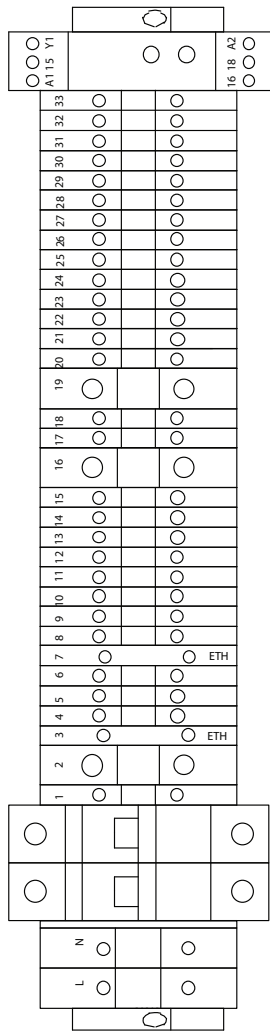

WATER IN/OUT CONNECTIONS 1" BSPM STUBS.
CONDENSATE CONNECTION 3/4" BSPM STUB.
ALLOW 500mm FOR ACCESS TO SERVICE PANELS

AIR OFF

TOP PANEL
(REMOVABLE)

AIR ON

EVAPORATOR
PANEL
(REMOVABLE)

AIR ON

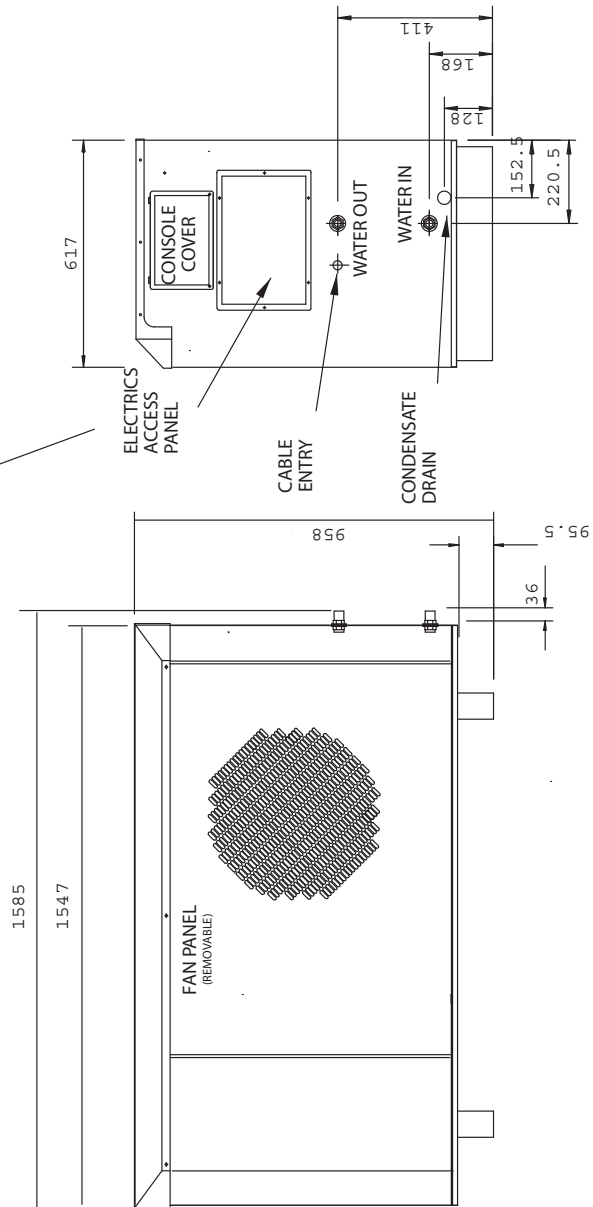

WARNING. DANGER FROM ELECTRIC SHOCK. ISOLATE ALL ELECTRICAL SUPPLIES BEFORE REMOVING ANY PANELS

INSTALLATION

SYSTEM DIAGRAMS -

Air Source Heat Pump Plumbing Circuits - S Plan (example) preferred method

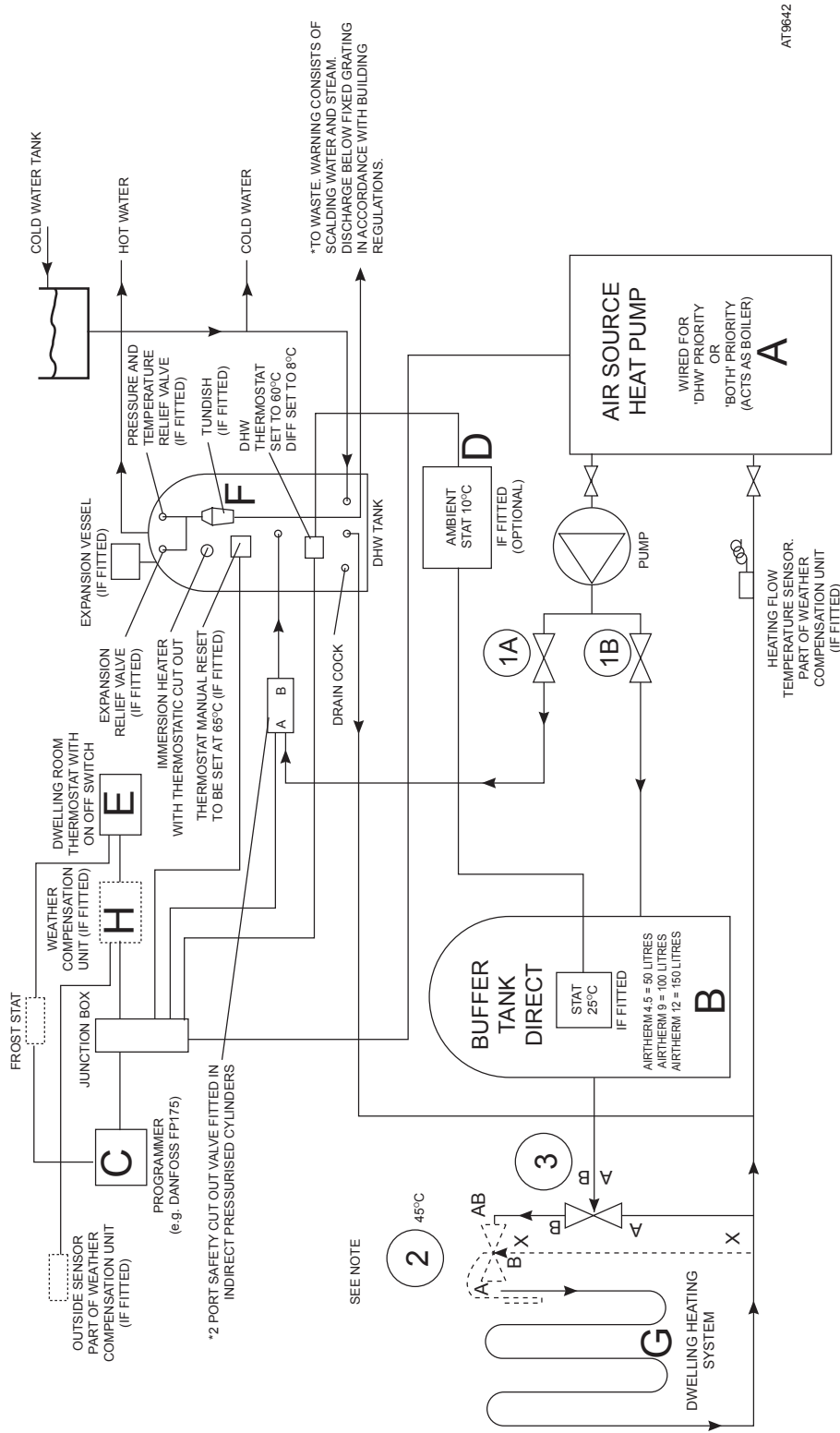

AT9842

*TO WASTE. WARNING CONSISTS OF SCALDING WATER AND STEAM. DISCHARGE BELOW FIXED GRATING IN ACCORDANCE WITH BUILDING REGULATIONS.

*2 PORT SAFETY CUT OUT VALVE FITTED IN INDIRECT PRESSURISED CYLINDERS

SEE NOTE

- ①A 2 PORT SPRING RETURN VALVE DHW
- ①B 2 PORT SPRING RETURN VALVE ROOM HEATING
- ② VALVE THERMOSTATIC FLOOR BYPASS VALVE (IF REQUIRED)
- ③ VALVE 'DEFROST' REQUIRED VALVE' = DIVERTER VALVE

NOTE: IF ROOM HEATING IS VIA RADIATORS RATHER THAN UNDERFLOOR HEATING THEM VALVE ② AND THE PIPE RUN X-X ARE NOT REQUIRED.

INSTALLATION

SYSTEM DIAGRAMS -

Air Source Heat Pump Plumbing Circuits - W Plan (example)

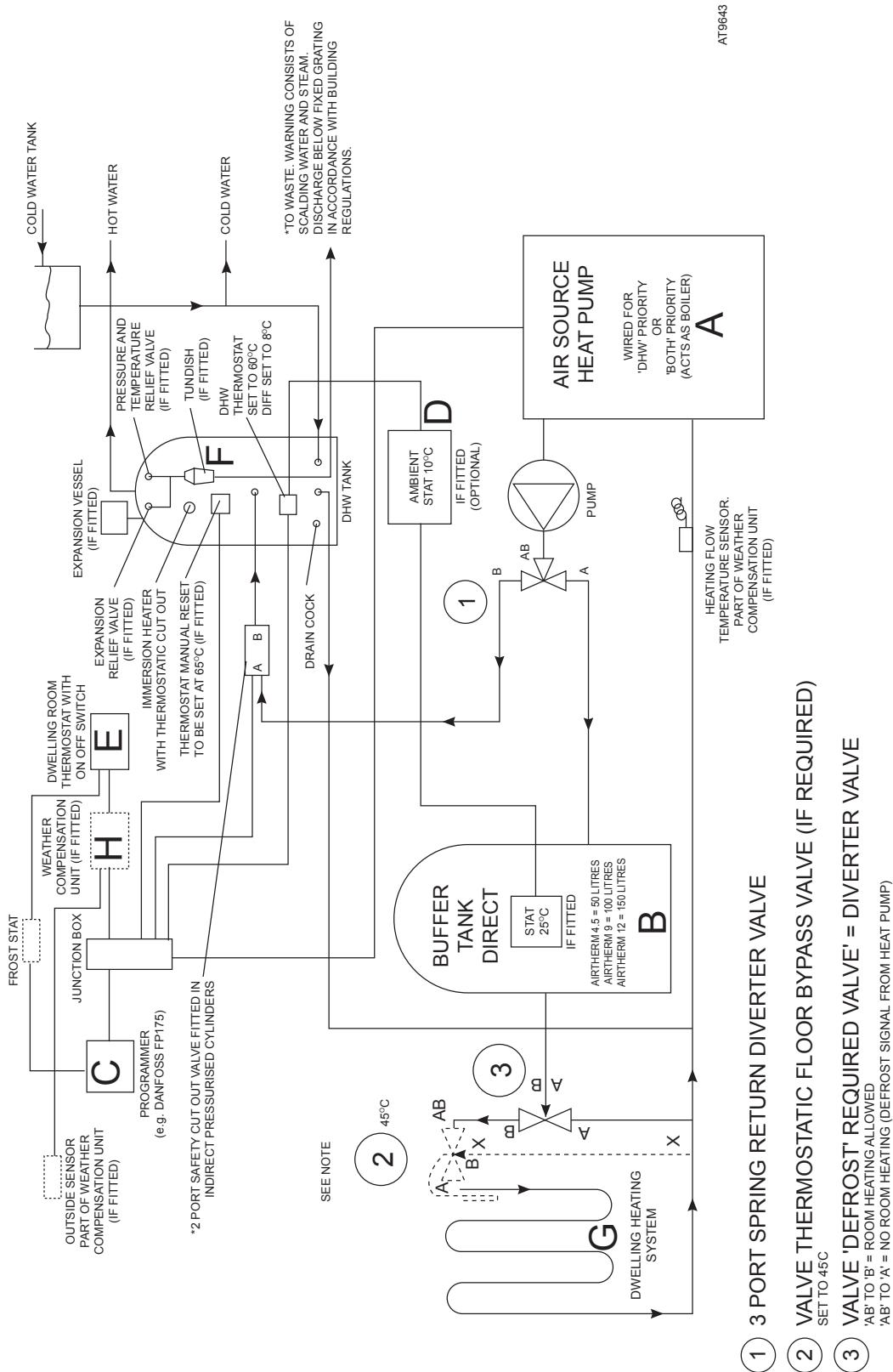

NOTE: IF ROOM HEATING IS VIA RADIATORS RATHER THAN UNDERFLOOR HEATING THEN VALVE ② AND THE PIPE RUN X-X ARE NOT REQUIRED.

INSTALLATION

SYSTEM DIAGRAMS -

External Wiring with Terminal Junction Box - W Plan

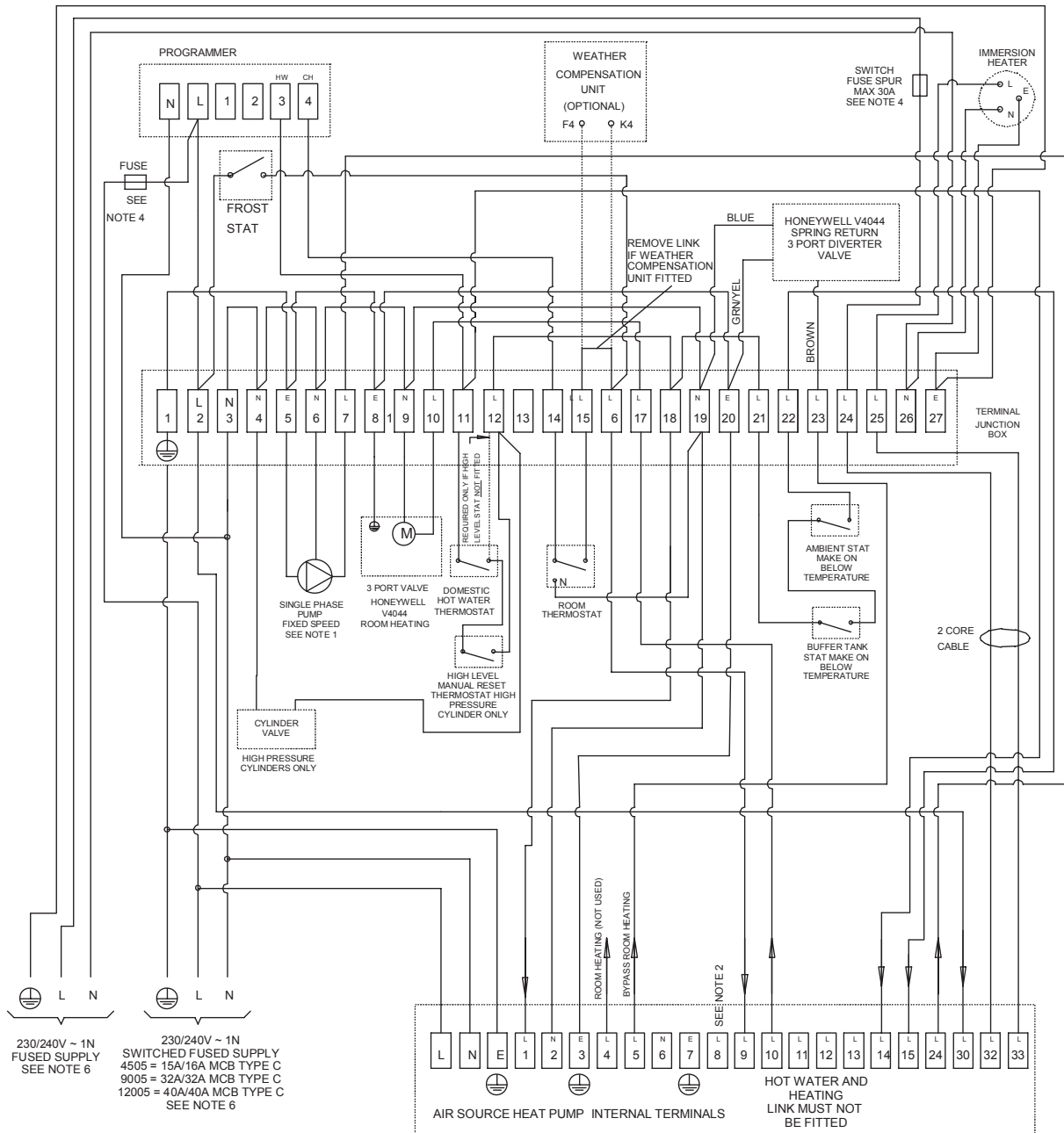

NOTES

- 1 MAXIMUM RATING OF CONTACTS FOR PUMP 1A. IF OVER 1A RELAY WILL NEED TO BE FITTED.
- 2 AIR SOURCE HEAT PUMP TERMINAL 8 IS CONTROL LIVE TEST TERMINAL.
- 3 ALL VALVES TO BE SPRING RETURN TYPE.
- 4 ALL EXTERNAL EQUIPMENT TO BE FUSED TO MANUFACTURERS RECOMMENDED FUSE SIZES.
- 5 MIN CABLE REQUIREMENTS 3 CORE MAINS CABLE, 12 CORE CONTROL CABLE
- 6 ASSOCIATED EXTERNAL EQUIPMENT AND MACHINE TO BE WIRED FROM SAME CONSUMER UNIT AND TAKEN FROM THE SAME PHASE AND NEUTRAL INCOMING SUPPLY.
- 7 WHEN FITTING BUFFER TANK THERMOSTATIC IMMERSION HEATING, THE IMMERSION THERMOSTAT MUST BE WIRED SO THAT IT CUTS OUT ON OVER TEMPERATURE, MAX SETTING 55°C

AT9647

IDEAL W PLAN GUIDE ONLY

INSTALLATION

BIVALENT INSTALLATION - SCHEMATIC DIAGRAM

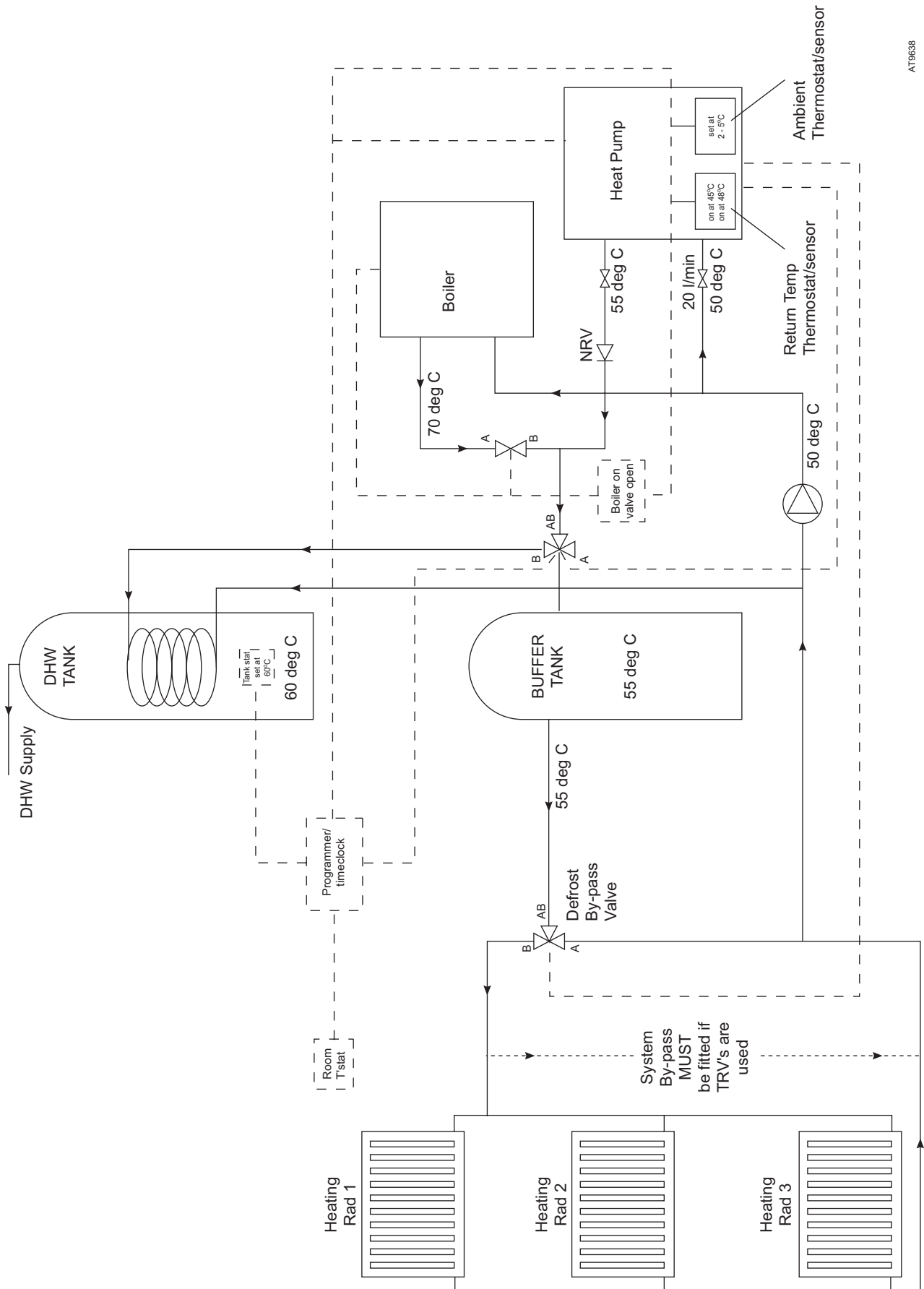

AT9638

INSTALLATION

REFRIGERATION DIAGRAM - AIRTHERM 4.5 & 9

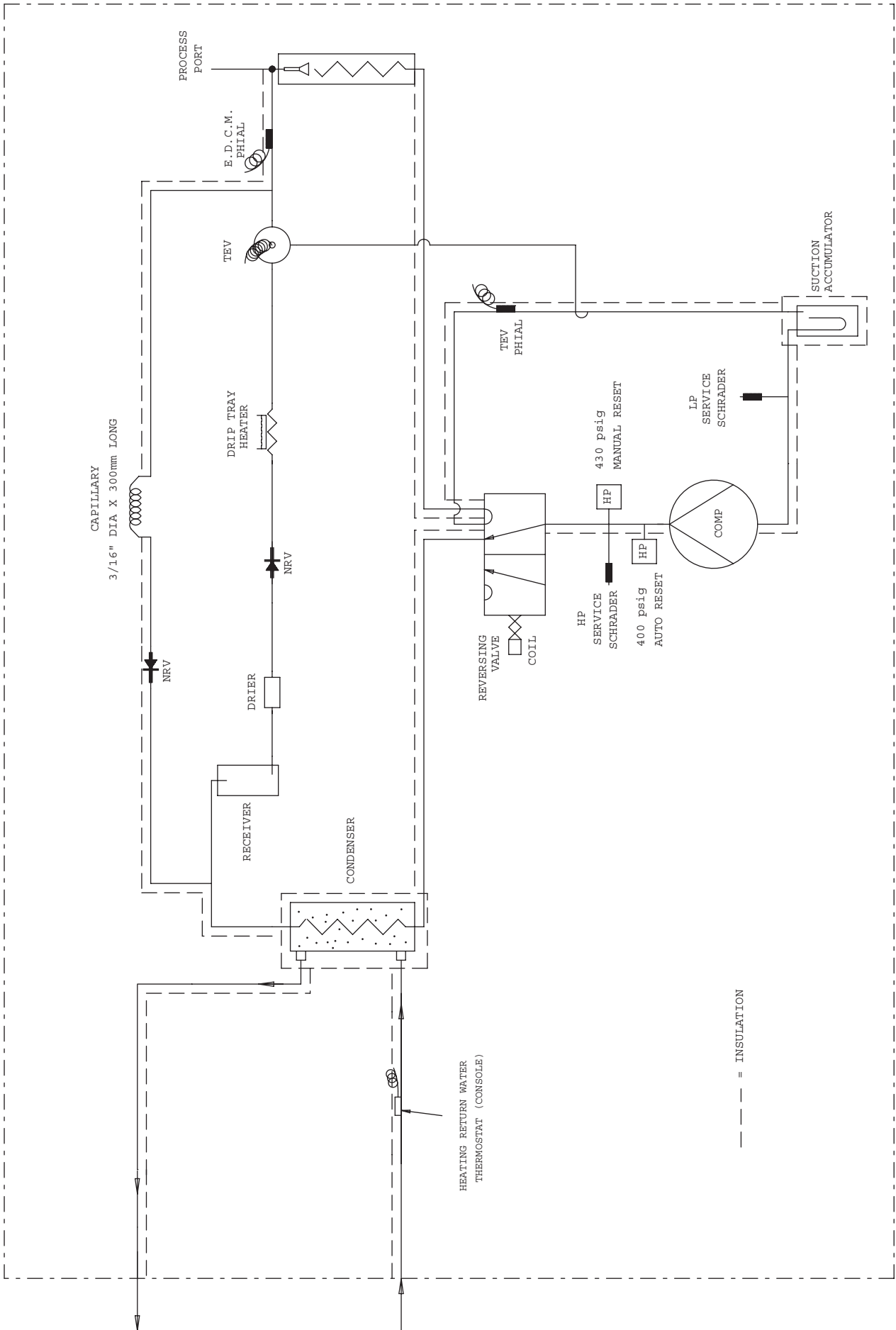

INSTALLATION

REFRIGERATION DIAGRAM - AIRTHERM 12

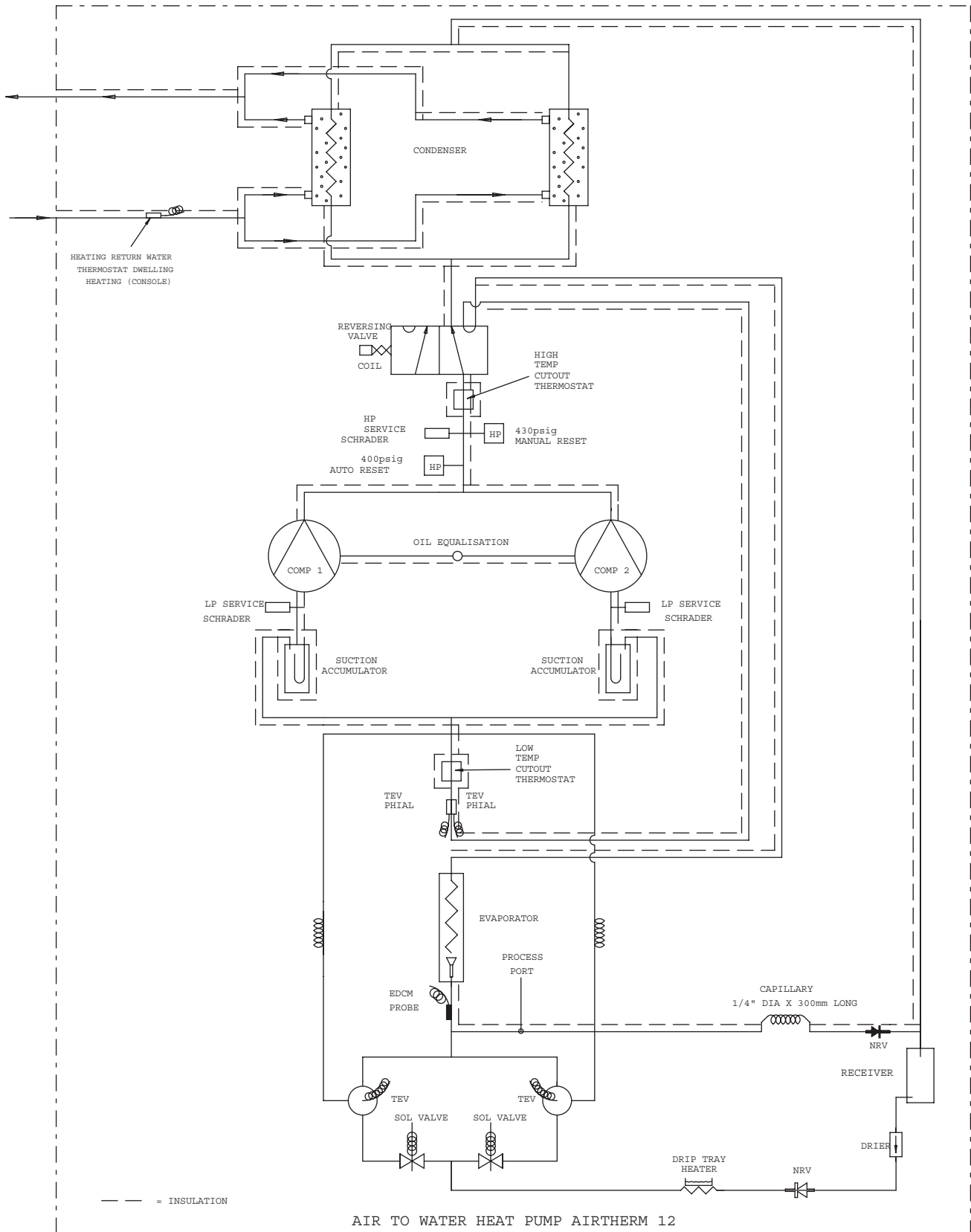

INSTALLATION

OPTIONAL WEATHER COMPENSATION

The use of a weather compensator with Ideal airtherm heat pumps achieves greater efficiency benefits.

An example of using the Siemens model RVP102 follows.

LEGEND

1. Setting potentiometer for switching differential.
2. Setting knob for heating curve slope.
3. Coding switches
4. Setting potentiometer for authority of room temperature for quick setback active/inactive.
5. Setting potentiometer for ECO heating limit.
6. Heating curve chart.

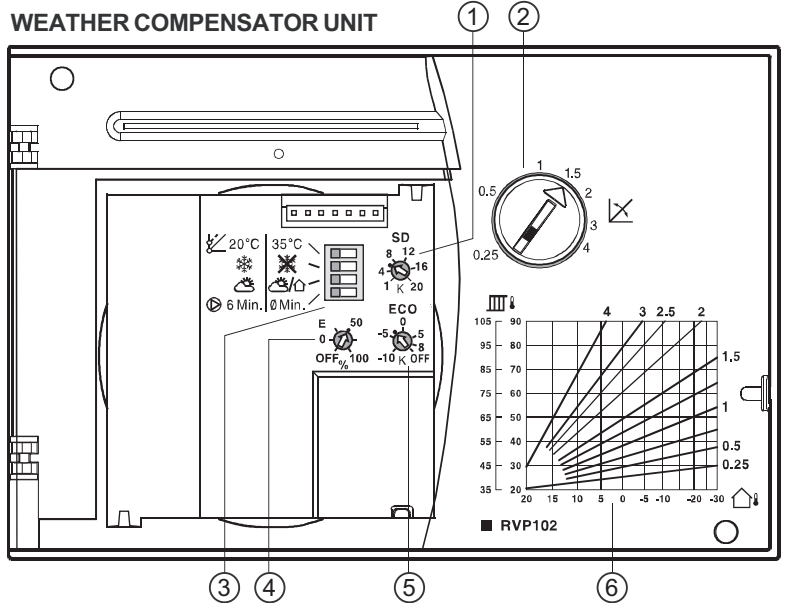

Coding switches (item ③)

FUNCTION	SWITCH POSITION ON LEFT	SYMBOL	SYMBOL	SWITCH POSITION ON LEFT	SUGGESTED SETTING
Base point of heating curve	Base point at 20°C flow temperature		35°C	Base point at 35°C flow temperature	Set to Left
Frost protection, yes/no	Yes, frost protection			No, no frost protection	Set to Right
Changeover of compensating variable, yes/no	No changeover: always weather compensated control and room temperature authority according to setting potentiometer E			Changeover to room temperature compensated control at reduced level	Set to Left
Pump overrun, yes/no	Six minute pump overrun		0 Min	0 minutes, no pump overrun	Set to Right

Setting potentiometers (items ①, ④, ⑤)

ITEM	POTENTIOMETER	FUNCTION	SETTING RANGE	GUIDE VALUE	SUGGESTED SETTING
1		Switching differential of heat pump temperature control	1...20 K	6 K	Set to 5 K
4		Authority of room temperature on heat pump temperature control	0...100 % authority OFF = quick setback is inactive	50 % (quick setback is active)	Set to OFF
5		Heating limit for ECO automatic energy saver	-10...+8 °C (referred to the room temperature setpoint)	-3 K (gives a heating limit of 16 °C at a room temperature setpoint of 20 °C)	Function disabled: OFF

MOUNTING THE SENSOR

Mounting Location

For optimisation the sensor must be positioned on the coldest wall of the house (normally wall facing north). The sensor must never be exposed to the morning sun.

Mounting Height

Preferably in middle of dwelling to be heated, but at least 2.5m above the ground.

Must not be fitted above windows, doors, air extracts or other heat sources, below balconies or in the eaves of the roof.

The sensor must not be painted over.

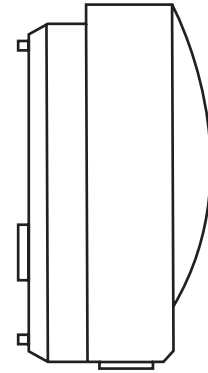

Outdoor Temperature Sensor

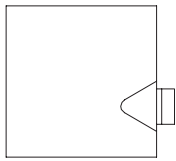

STRAP ON TEMPERATURE SENSOR

MOUNTING POSITIONS

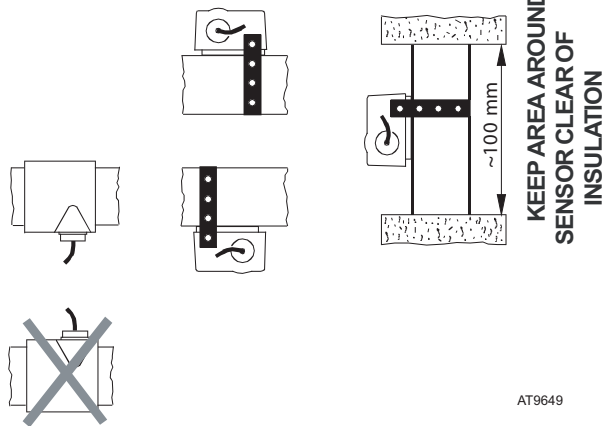

AT9649

WIRING THE OPTIONAL WEATHER COMPENSATOR (see external wiring diagram)

Notes.

1. Room thermostat enables heating pump
2. Assumed that domestic hot water will have priority and override heating circuit.
3. If using Grundfos control box, terminal numbers are different, see external wiring diagram.

Cable lengths

PERMISSIBLE CABLE LENGTHS TO DETECTORS AND ROOM UNIT	
CABLE SIZE	CABLE LENGTH
COPPER CABLE Ø0.6mm	30m
COPPER CABLE 0.5mm ²	50m
COPPER CABLE 1.0mm ²	80m
COPPER CABLE 1.5mm ²	120m

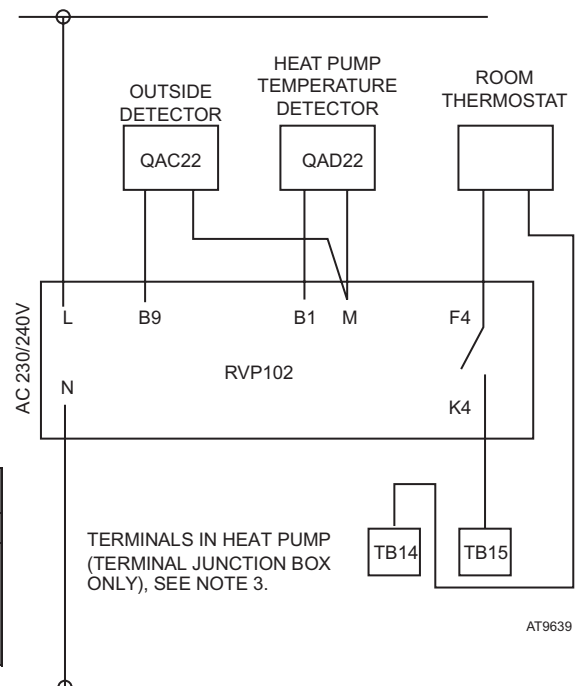

AT9639

HEAT PUMP BUFFER INSTALLATION REQUIREMENTS

There are a number of main points that affect the buffer sizing requirements as follows:

1. A constant water flow of +/- 10% of design must be maintained through the heat pump. This can be achieved using good system design. Where TRV's or underfloor heating are used special care must be taken to ensure the flow is maintained regardless of system turn down.
2. The assumptions using combination cylinders in table1 assume that the buffer vessel is plumbed in series with the radiator circuitry simply adding water volume to assist flow rates.
3. Table 2 shows the temperature drop in the water volume in the buffer and the heat distribution circuit as a result of providing energy for the heat pump to perform defrost functions when necessary.

Table 1

Heat Pump	System Type	TRV's fitted	Flow rate required l/m	System water volumes	Buffer tank	Minimum size of buffer	Method proposed	Minimum DHW Cylinder	Normal DHW Cylinder	Max DHW size	Minimum Circulation Pump Size	No of Pumps on system	Typical System Design
4.5kW	radiators	no	7.5	above 45 litres	No	n/a	DHW cylinder only	150 litre	150 litre	180 litre	15 - 50	1	S or W Plan
4.5kW	radiators	no	7.5	below 45 litres	Yes	50 litres	combination cylinder	150 litre	150 litre	180 litre	15 - 50	1	S or W Plan
4.5kW	radiators	yes	7.5	n/a	Yes	50 litres	combination cylinder	150 litre	150 litre	180 litre	15 - 50	1	S or W Plan
4.5kW	underfloor	n/a	7.5	n/a	Yes	50 litres	separate cylinder /buffer	150 litre	150 litre	180 litre	15 - 50	2	2 pump system
9.0kW	radiators	no	15	above 80 litres	No	n/a	DHW cylinder only	150 litre	180 litre	250 litre	15 - 60	1	S or W Plan
9.0kW	radiators	no	15	below 80 litres	Yes	50 litres	combination cylinder	150 litre	180 litre	250 litre	15 - 60	1	S or W Plan
9.0kW	radiators	Yes	15	n/a	Yes	50 litres	combination cylinder	150 litre	180 litre	250 litre	15 - 60	1	S or W Plan
9.0kW	underfloor	n/a	15	n/a	Yes	95 litres	separate cylinder /buffer	150 litre	180 litre	250 litre	15 - 60	2	2 pump system
12kW	radiators	no	20	above 160 litres	No	n/a	combination cylinder	150 litre	210 litre	250 litre	15 - 60	1	S or W Plan
12kW	radiators	no	20	above 110 litres	Yes	50 litres	combination cylinder	150 litre	210 litre	250 litre	15 - 60	1	S or W Plan
12kW	radiators	no	20	below 110 litres	Yes	95 litres	combination cylinder	150 litre	210 litre	250 litre	15 - 60	1	S or W Plan
12kW	radiators	Yes	20	n/a	Yes	95 litres	combination cylinder	150 litre	210 litre	250 litre	15 - 60	1	S or W Plan
12kW	underfloor	n/a	20	n/a	Yes	150 litres	separate cylinder /buffer	150 litre	210 litre	250 litre	15 - 60	2	2 pump system

Table 2 - Defrost Times & Temperature Drops

Model	Operation Condition	Defrost Times - mins	System Volume - ltrs	System temp drop - °C**
4.5	A5/W55	5	45	4.9
4.5	A0/W55	6	45	3.9
4.5	A-3/W55	7	45	3.8
9	A5/W55	5	80	5.5
9	A0/W55	6	80	4.4
9	A-3/W55	7	80	4.3
12	A5/W55	5	110	5.5
12	A0/W55	6	110	4.4
12	A-3/W55	7	110	4.2

** Estimated from defrost tests carried out

Water Storage Requirement

The heating circulation pump takes hot water from the Airtherm unit to the thermstore water storage vessel which is a specially designed indirect cylinder.

The following range of cylinders are available from Ideal heating. These are fitted with thermostatic controls which control the storage water temperature. The maximum DHW temperature is set in the factory at 65°C.

Sealed Systems - Installation must comply with the requirements of BS6798 and BS5449.

Installations must be designed in excess of the maximum system operating temperature and pressures.

Safety valves must comply with BS6759.

All system components must comply with the required local water regulations.

Thermstore Cylinders Pressure Data

1. Inlet control to 2.1 bars (by the valve provided)
2. The venting pressure 3.5 bars (by the valve provided)
3. The maximum operating pressure is 3 bars

Thermstore Coil Pressure Data

1. Coil is rated to 3.5 bars
2. Maximum operating pressure 3 bars

Thermstore Unvented (indirect) Cylinder

Cylinder Type	Shell size (mm)	Overall dimensions(mm)	Ideal No
150 Litre	1100 x 450	1125 x 550	204829
180 Litre	1300 x 450	1325 x 550	204830
210 Litre	1500 x 450	1525 x 550	204831

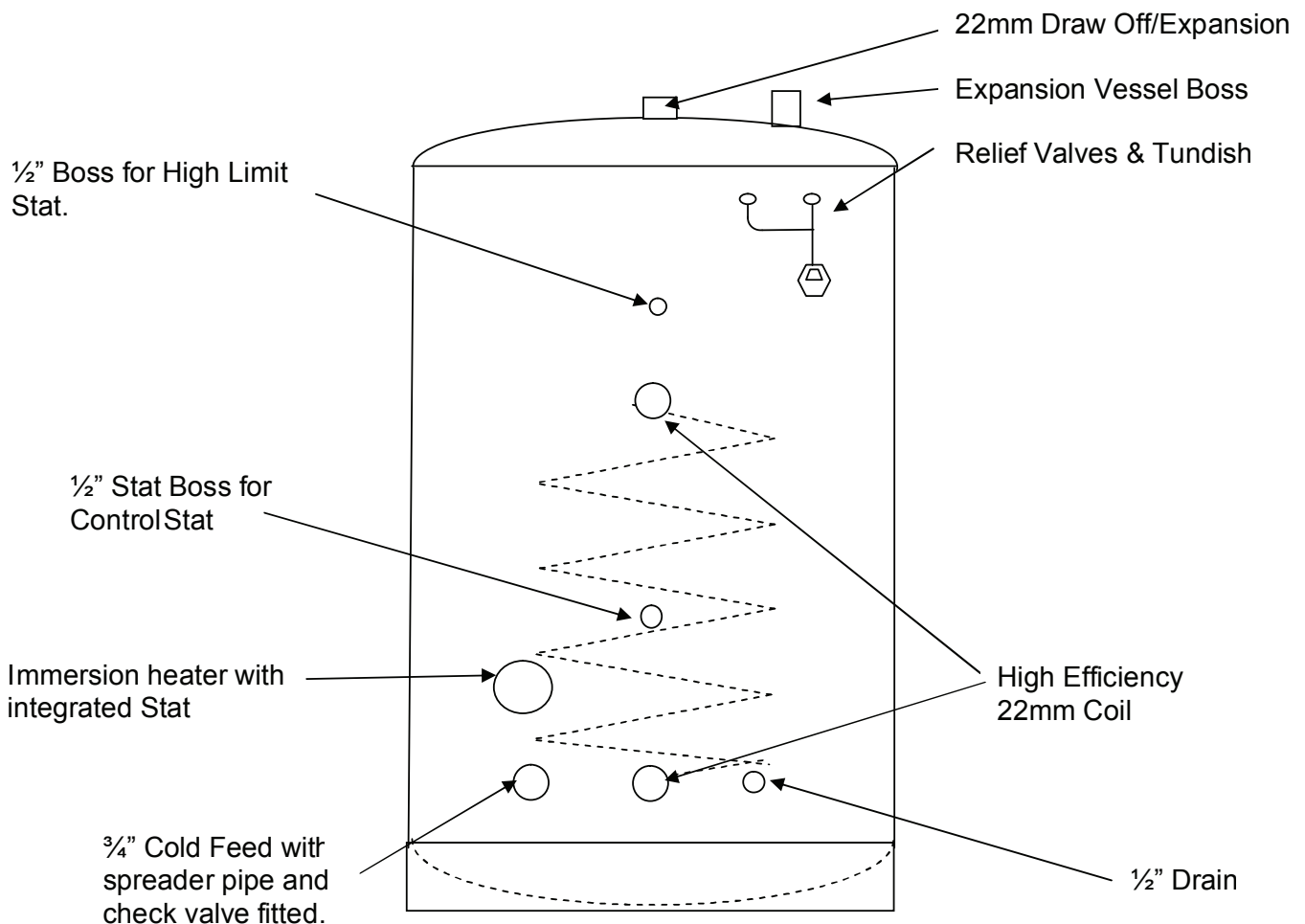

Thermstore Unvented (direct) Buffer & (indirect) Cylinder Combined

Cylinder Type	Shell size (mm)	Overall dimensions(mm)	Ideal No
50/150 Litre	1500 x 450	1525 x 550	204835
95/180 Litre	2100 x 450	2125 x 550	204836
150/210 Litre	2150 x 500	2175 x 550	204837

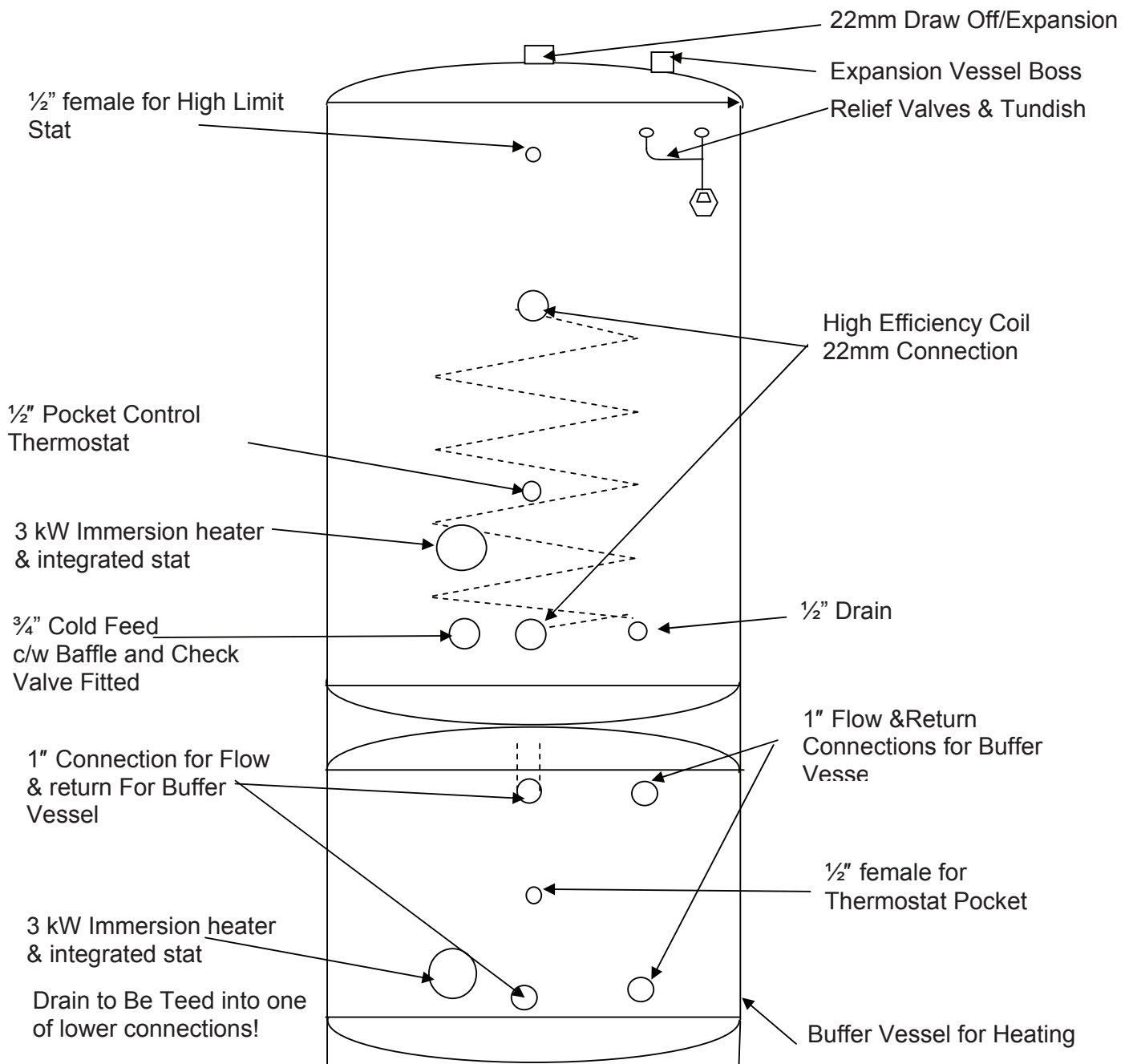

Thermstore Unvented (direct) Buffer Cylinder

Cylinder Type	Shell size (mm)	Finished Size	Ideal No
50L Direct	450 x 450	475 x 550	204832
95L Direct	750 x 450	775 x 550	204833
150L Direct	900 x 500	925 x 600	204834

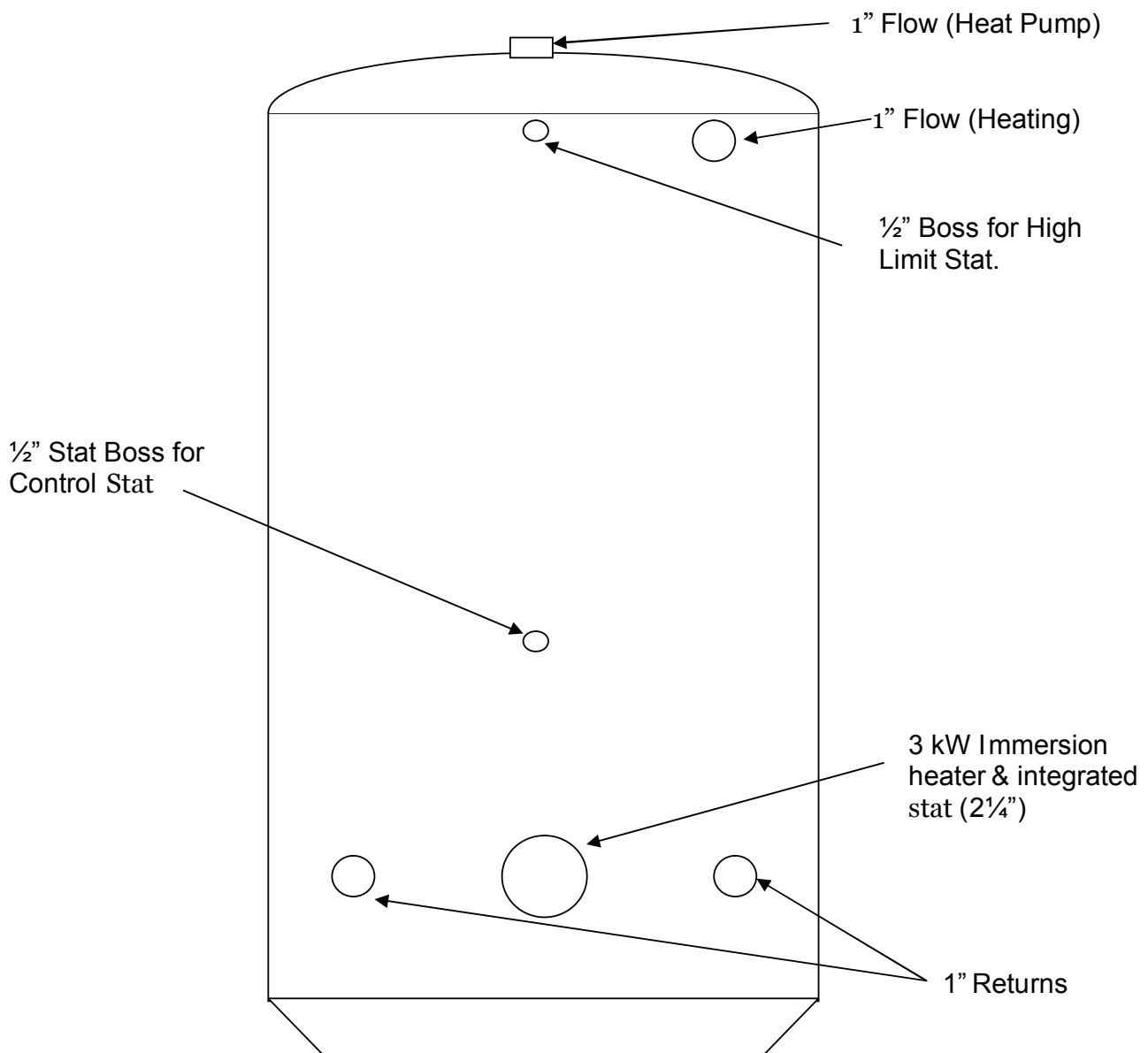

Service Record

It is recommended that your heating system is serviced regularly and that the appropriate Service Interval Record is completed.

Service Provider

Before completing the appropriate Service Interval Record below, please ensure you have carried out the service as described in the manufacturer's instructions.

Always use the manufacturer's specified spare part when replacing controls.

Service 1

Date: _____

Engineer Name: _____

Company Name: _____

Telephone No. _____

Operative ID No. _____

Comments: _____

Signature: _____

Service 2

Date: _____

Engineer Name: _____

Company Name: _____

Telephone No. _____

Operative ID No. _____

Comments: _____

Signature: _____

Service 3

Date: _____

Engineer Name: _____

Company Name: _____

Telephone No. _____

Operative ID No. _____

Comments: _____

Signature: _____

Service 4

Date: _____

Engineer Name: _____

Company Name: _____

Telephone No. _____

Operative ID No. _____

Comments: _____

Signature: _____

Service 5

Date: _____

Engineer Name: _____

Company Name: _____

Telephone No. _____

Operative ID No. _____

Comments: _____

Signature: _____

Service 6

Date: _____

Engineer Name: _____

Company Name: _____

Telephone No. _____

Operative ID No. _____

Comments: _____

Signature: _____

Service 7

Date: _____

Engineer Name: _____

Company Name: _____

Telephone No. _____

Operative ID No. _____

Comments: _____

Signature: _____

Service 8

Date: _____

Engineer Name: _____

Company Name: _____

Telephone No. _____

Operative ID No. _____

Comments: _____

Signature: _____

Service 9

Date: _____

Engineer Name: _____

Company Name: _____

Telephone No. _____

Operative ID No. _____

Comments: _____

Signature: _____

Service 10

Date: _____

Engineer Name: _____

Company Name: _____

Telephone No. _____

Operative ID No. _____

Comments: _____

Signature: _____

Technical Training

The Ideal Boilers Technical Training Centre offers a series of first class training courses for domestic, commercial and industrial heating installers, engineers and system specifiers.
For details of courses please ring:..... 01482 498 432



FM 59915

Manufactured under an ISO 9001 registered quality management system

Ideal Boilers, P.O. Box 103, National Ave, Kingston upon Hull, HU5 4JN. Telephone: 01482 492 251 Fax: 01482 448 858. Registration No. London 322 137.

Ideal Stelrad Group pursues a policy of continuing improvement in the design and performance of its products. The right is therefore reserved to vary specification without notice.



***i* Ideal** BOILERS
The High Efficiency Pioneers



Ideal Stelrad Group

www.idealboilers.com